

# MASTECH®



## CATALOGUE 2021



MGL®

MEASURING INSTRUMENTS CATALOGUE

**CONTENT INDEX**

<b>2</b>	WHO IS MGL
<b>3</b>	ABOUT MASTECH
<b>4</b>	FAST SELECTION CHARTS
<b>23</b>	DIGITAL MULTIMETERS
<b>45</b>	DIGITAL CLAMP METERS
<b>63</b>	ELECTRICAL TESTER
<b>73</b>	CIRCUIT TESTERS
<b>77</b>	CIRCUIT ANALYZERS
<b>81</b>	WIRE & CABLE TESTERS
<b>87</b>	EARTH RESISTANCE
<b>91</b>	LCR METERS
<b>97</b>	INSULATION TESTERS
<b>101</b>	PAT TESTER
<b>103</b>	THERMOMETERS
<b>115</b>	ENVIRONMENTAL METERS
<b>134</b>	ACCESSORIES

## WHO IS MGL

We are a global group of companies operating locally. We manufacture test and measurement products for the electrical and automotive industry, from the entry level through high tech products.

Our companies work globally, serving our customers worldwide. This global network delivers a deeper understanding of each individual market, with solutions tailored to the unique requirements of each customer.

With customers over 20 years old, our goal is to be a recognized, honest and fair company. We aim to be the most valued partner for our customers in the research, development, manufacture and supply of innovative, modern and customer-focused technologies.

We have a highly experienced team which is openminded, receptive to new ideas and adaptive to evolving market trends. This solid foundation guarantees that we are well informed and fully equipped to deliver excellent solutions to meet our customers' real needs.



## BRANDING CHANNELS

We manufacture electrical test and measurement instruments under our own brands: Mastech, KPS, C-Logic and Power Probe, recognized brands and market leaders in the fields of electrical measurement and automotive. All of our products have a professional positioning based on advanced balanced technology and they are marketed through local distributors throughout the world. We maintain direct and close contact with our distributors, through our offices around the world, and we support them in their business by offering technical advice and an after-sales service for our products.

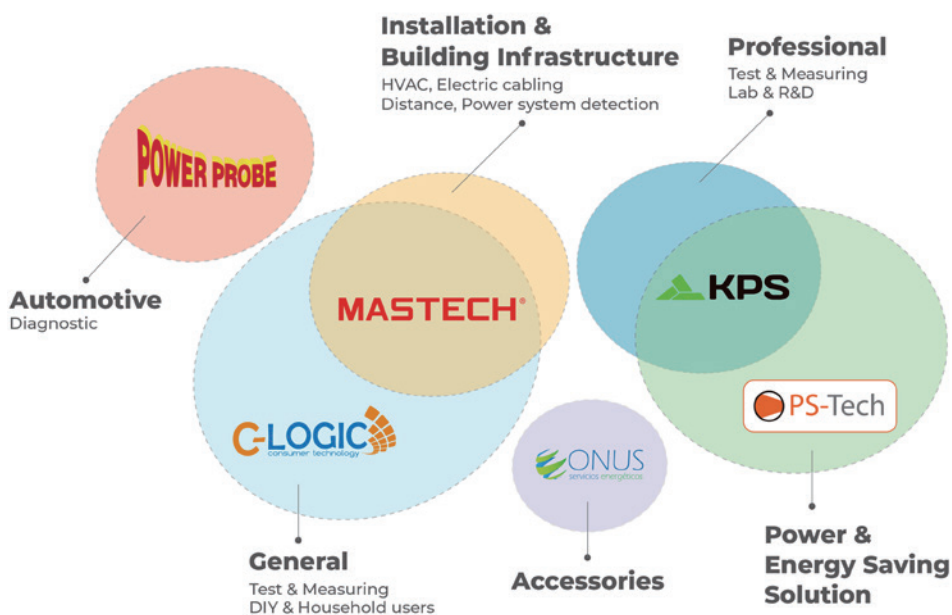

# MASTECH®

At MASTECH we focus on providing the highest quality, innovative measuring instruments for the electrical market, along with the best service to our customers.





From digital multimeters and clamp meters to voltage testers, plug testers and all ranges of environmental testers, our product families have been developed to meet the requirements of the construction, DIY and industrial sectors.

## Test and measurement equipment:

- I. For industrial environments: we develop a range of measuring instruments with specific features and high precision, ensuring reliability and accuracy.
- II. For the residential sector: MASTECH instruments meet all requirements relating to measuring and testing of electrical values, enabling safety checks on installations and appliances in homes and other buildings.
- III. For environmental measurement, MASTECH offers a wide range of solutions, with measuring instruments for temperature, moisture and wind speed to light, sound, gas and distance.



DIGITAL MULTIMETERS  
**MANUAL RANGING**

					
CAT II CAT III CAT IV					
Model	MS8301A	MS8301B	MY70	MY74	MY75
Page	24	25	26	27	28
Safety Rating	CAT III 600V	CAT III 600V	CAT III 600V	CAT III 600V	CAT III 600V
Display Counts	2000	4000	2000	2000	20000
Auto Ranging	•	•			
Auto Power Off	•	•	•	•	•
True RMS					
DC Voltage	600v	600v	600V	600V	600V
AC Voltage	600v	600v	600V	600V	600V
DC Current	10A	10A	10A	10A	10A
AC Current	10A	10A	10A	10A	10A
Resistance	2MΩ	40MΩ	200MΩ	200MΩ	200MΩ
Capacitance		100μF		100μF	100μF
Frequency		100kHz		20kHz	20kHz
Duty Cycle					
Type K Temperature		-20~1000°C -4~1832°F		-20~1000°C	
Battery Test	•				
Diode	•	•	•	•	•
Continuity	•	•	•	•	•
Display Backlight		•			
Work Light		•			
Data Hold	•	•	•	•	•
NCV		•			
Inductance					
hFE Transistor			•	•	
Dual Display					
MAX					
MAX/MIN					
MAX/MIN/AVG					
Relative Measurement					
Peak Measurement					
DWELL Test					
TACH Test					
Certificate	CE/ETL	CE/ETL	CE/ETL	CE/ETL	CE/ETL



## DIGITAL MULTIMETERS AUTO RANGING

CAT II  
CAT III  
CAT IV



Model	MS8238H	MS8251A	MS8301D	MS8332C
Page	29	30	31	32
Safety Rating	CAT III 600V	CAT III 1000V CAT IV 600V	CAT III 600V	CAT III 600V
Display Counts	4000	6600	6000	4000
Auto Ranging	•	•	•	•
Auto Power Off	•	•	•	•
True RMS	•			
DC Voltage	600V	1000V	600V	600V
AC Voltage	600V	1000V	600V	600V
DC Current	10A	10A		400mA
AC Current	10A	10A		400mA
Resistance	40MΩ	66MΩ	10MΩ	400MΩ
Capacitance		66μF		100μF
Frequency		66Hz	3kHz	5MHz
Duty Cycle		•	•	•
Type K Temperature	-20~1000°C -4~1832°F	0~1000°C 32~1832°F		
Battery Test	•			
Diode	•	•		•
Continuity	•	•	•	•
Display Backlight		•	•	•
Work Light				
Data Hold	•	•	•	•
NCV	•	•	•	•
Inductance				
hFE Transistor				
Dual Display		•	•	
MAX				
MAX/MIN		•	•	
MAX/MIN/AVG				
Relative Measurement		•		
Peak Measurement				
Low Pass Filter				
AC/DC Current (For Clamp)				
Low Impedance				
Bar Graph				
Interface	Wireless			
Certificate	CE/ETL	CE/ETL	CE/ETL	CE/ETL

### DIGITAL MULTIMETERS AUTO RANGING

			
CAT II CAT III CAT IV			
Model	MS8340A	MS8361D	MY78
Page	33	34	35
Safety Rating	CAT III 1000V	CAT III 600V	CAT II 1000V CAT III 600V
Display Counts	6000	4000	4000
Auto Ranging	•	•	•
Auto Power Off	•	•	•
True RMS		•	
DC Voltage	1000V	600V	600V
AC Voltage	750V	600V	600V
DC Current	10A	10A	10A
AC Current	10A	10A	10A
Resistance	60MΩ	40MΩ	200MΩ
Capacitance	400μF	100μF	100μF
Frequency	10MHZ	10MHZ	20kHz
Duty Cycle	•	•	•
Type K Temperature	-10~700°C 14~1292°F		
Battery Test			
Diode	•	•	•
Continuity	•	•	•
Display Backlight	•	•	
Work Light			
Data Hold	•	•	•
NCV		•	
Inductance			
hFE Transistor		•	•
Dual Display			
MAX			
MAX/MIN	•		
MAX/MIN/AVG			
Relative Measurement	•	•	•
Peak Measurement			
Low Pass Filter	•		
AC/DC Current (For Clamp)			•
Low Impedance			
Bar Graph			
Interface		Wireless	
Certificate	CE/ETL	CE/ETL	CE/ETL

DIGITAL MULTIMETERS  
**POCKET/PEN TYPE**

CAT II  
CAT III  
CAT IV



Model	MS8333A	MS8211	MS8211D	MS8212A
Page	36	37	38	39
Safety Rating	CAT III 600V	CAT II 600V	CAT II 600V	CAT III 600V
Display Counts	6000	2000	2000	2000
Auto Ranging	•	•	•	•
Auto Power Off	•	•	•	•
True RMS	•			
DC Voltage	600V	600V	600V	600V
AC Voltage	600V	600V	600V	600V
DC Current	600mA		200mA	200mA
AC Current	600mA		200mA	200mA
Resistance	60MΩ	20MΩ	20MΩ	20MΩ
Capacitance	600μF			
Frequency	10kHz			
Duty Cycle	•			
Type K Temperature				
Battery Test	•			
Diode	•	•	•	•
Continuity	•	•	•	•
Display Backlight	•			
Work Light				
Data Hold	•	•	•	•
NCV	•	•		•
Inductance				
hFE Transistor				
Dual Display				
MAX		•	•	•
MAX/MIN				
MAX/MIN/AVG				
Relative Measurement				
Peak Measurement				
DWELL Test				
TACH Test				
Logic Level Test			•	•
Retractable Tip		•	•	
Double Molding				•
Certificate	CE/ETL	CE	CE	CE



### DIGITAL MULTIMETERS BENCH TYPE

CAT II  
CAT III  
CAT IV



Model	MS6100	MS8040	MS8050
Page	40	41	42
Safety Rating		CAT II 1000V	CAT II 1000V
Display Counts	22000	22000	53000
Auto Ranging	•	•	•
Auto Power Off		•	•
True RMS		•	•
DC Voltage		1000V	1000V
AC Voltage		750V	1000V
DC Current		10A	10A
AC Current		10A	10A
Resistance		200MΩ	50MΩ
Capacitance		200mF	5mF
Frequency	1300MHz		
Logic Frequency		220MHz	2MHz
Linear Frequency		100kHz	200kHz
Duty Cycle		•	•
OSC. Out	10MHz		
Type K Temperature		-30~1300°C	
Diode		•	•
hFE Transistor			
Continuity		•	•
Backlight		•	•
Data Hold	•	•	•
MAX/MIN/AVG		MAX/MIN	•
Relative Measurement	•	•	•
Peak Measurement		•	
Low Pass Filter	•	•	
Bar Graph		•	
DC Current (For Clamp)		220/2200A	
AC Current (For Clamp)		220/2200A	
ADP measurement			
Data Logging			30 Groups
Analysis Software			•
Interface		USB	USB
Certificate	CE	CE	CE







## DIGITAL MULTIMETERS SPECIAL APPLICATION

CAT II  
CAT III  
CAT IV







Model	MS5208	MS8239D
Page	43	44
Safety Rating	CAT III 1000V CAT IV 600V	CAT III 600V
Display Counts	6600	2000
Auto Ranging	•	•
Auto Power Off	•	•
True RMS	•	
DC/AC Voltage	1000V/750V	600V/600V
DC/AC Current	400mA/400mA	10A/10A
Resistance	60MΩ	20MΩ
Capacitance	600mF	
Frequency	10kHz	
Duty Cycle	•	
Diode	•	•
Type K Temperature	-30~1300°C -22~2372°F	
Continuity	•	•
Display Backlight	•	•
Data Hold	•	•
NCV		
hFE Transistor		
MAX		•
MAX/MIN		
MAX/MIN/AVG	•	
Relative Measurement	•	
Low Pass Filter	•	
Insulation Test	1000V/2GΩ	
DAR/PI	•	
Relative Humidity		
Sound level		
Luminosity		
Sound & Light Warning		
Data Logging	100 Groups	
Interface		
DWELL/TACH Test		
Certificate	CE/ETL	CE/ETL

### DIGITAL CLAMP METERS AC CURRENT

							
Model	MS2009A	MS2009C	MS2025A	MS2025C	MS2028A	MS2030B	MS2033A
Page	46	47	48	49	50	51	52
Safety Rating	CAT III 600V	CAT III 600V	CAT III 1000V CAT IV 600V	CAT III 1000V CAT IV 600V	CAT III 600V	CAT III 600V	CAT III 600V
Display Counts	2000	6000	6000	6600	2000	4000	6000
Jaw Size	Φ26mm 1.0"	Φ26mm 1.0"	Φ40mm 1.6"	Φ40mm 1.6"	Φ26mm 1.0"	Φ28mm 1.1"	Φ26mm 1.0"
Auto Ranging	•	•	•	•	•	•	•
Auto Power Off	•	•	•	•	•	•	•
True RMS			•	•	•		
DC Voltage	600V	600V	1000V	1000V	600V	600V	600V
AC Voltage	600V	600V	750V	750V	600V	600V	600V
DC Current							
AC Current	600A	600A	1000A	1000A	600A	600A	600A
Inrush Current							
Resistance	20MΩ	60MΩ	60MΩ	66MΩ	20MΩ	40MΩ	10MΩ
Capacitance		60mF	100mF	66mF		100μF	
Frequency		10MHz	10MHz	66MHz		10kHz	3kHz
Duty Cycle		•	•	•			•
Type K Temperature		-20~1000°C -4~1832°F		-20~1000°C -4~1832°F		-20~1000°C -4~1832°F	
Diode	•	•	•	•	•	•	
Continuity	•	•	•	•	•	•	•
Display Backlight	•	•	•	•	•	•	•
Work Light	•	•	•	•		•	
Data Hold	•	•	•	•	•	•	•
NCV	•	•	•	•		•	
MAX/MIN	MAX		•	•	Max		•
Relative Measurement			•	•			
Bar Graph				•			
Insulation Test							
DC Current (From Plug)							
Low Pass Filter							
Low Impedance							
Dual Display				•			•
Infrared Temperature							
Interface							
Certificate	CE/ETL	CE/ETL	CE/ETL	CE/ETL	CE/ETL	CE/ETL	CE/ETL

## DIGITAL CLAMP METERS AC/DC CURRENT

					
CAT II CAT III CAT IV					
Model	MS2109A	MS2125A	MS2128	MS2128A	MS2160
Page	53	54	55	56	57
Safety Rating	CAT III 600V	CAT III 1000V CAT IV 600	CAT III 600V	CAT III 600V	CAT III 1000V CAT IV 600
Display Counts	6000	6000	6600	4000	4000
Jaw Size	Φ26mm 1.0"	Φ40mm 1.6"	Φ26mm 1.0"	Φ26mm 1.0"	Φ24mm 0.9"
Auto Ranging	•	•	•	•	•
Auto Power Off	•	•	•	•	•
True RMS		•	•	•	
DC Voltage	600V	1000V	600V	600V	600V
AC Voltage	600V	750V	600V	600V	600V
DC Current	600A	1000A	400A	400A	80A
AC Current	600A	1000A	400A	400A	80A
Inrush Current		1000A	600A		
Resistance	60MΩ	60MΩ	40MΩ	40MΩ	40MΩ
Capacitance	4mF	100mF	4000uF	4mF	40mF
Frequency	10MHz	10MHz	10kHz	10kHz	10MHz
Duty Cycle	•	•	•	•	•
Type K Temperature	-20~1000°C -4~1832°F				-20~1000°C -4~1832°F
Diode	•	•	•	•	•
Continuity	•	•	•	•	•
Display Backlight	•	•	•	•	•
Work Light	•	•	•	•	•
Data Hold	•	•	•	•	•
NCV	•	•			•
MAX/MIN	•	•	•	•	
Relative Measurement	•	•		•	
Bar Graph				•	
Insulation Test					
DC Current (From Plug)					
Low Pass Filter					
Low Impedance					
Dual Display					
Infrared Temperature					
Interface					
Certificate	CE/ETL	CE/ETL	CE/ETL	CE/ETL	CE/ETL

DIGITAL CLAMP METERS  
**SPECIAL APPLICATION**



DIGITAL CLAMP METERS  
**LEAKGE**

CAT II  
CAT III  
CAT IV



Model	MS2601	MS2016A
Page	58	59
Safety Rating	CAT III 600V	CAT III 600V
Display Counts	6000	4000
Jaw Size	Φ12mm 0.5"	Ø30mm 1.2"
Auto Ranging	•	•
Auto Power Off	•	•
True RMS		•
DC Voltage	600V	600V
AC Voltage	600V	600V
AC Current	200A	150A
Inrush Current		
Resistance	60MΩ	40MΩ
Capacitance	60mF	40mF
Frequency	60MHz	
Duty Cycle		
Type K Temperature	-20~400°C / -4~750°F	
Diode	•	•
Continuity	•	•
Display Backlight	•	
Work Light	•	
Data Hold	•	•
NCV	•	
MAX/MIN		•
Relative Measurement		
Bar Graph		
DC Current (From Plug)	1000μA	
Low Impedance	•	
Active Power		
Apparent Power		
Reactive Power		
Power Factor		
Active Energy		
Harmonic Measurement		
Data Logging		
Interface		
Certificate	CE/ETL	CE/ETL





## DIGITAL CLAMP METERS POWER

			
	<b>CAT II</b> <b>CAT III</b> <b>CAT IV</b>		
Model	MS2203	MS2205	MS2225A
Page	60	61	62
Safety Rating	<b>CAT III 600V</b>	<b>CAT III 600V</b>	<b>CAT III 1000V</b> <b>CAT IV 600</b>
Display Counts	9999	6000	6000
Jaw Size	Φ50mm 2.0"	Φ50mm 2.0"	Φ40mm 1.6"
Auto Ranging	•	•	•
Auto Power Off		•	•
True RMS	•	•	•
DC Voltage			1000V
AC Voltage	600V	600V	750V
AC Current	1000A	1000A	1000A
Inrush Current			1000A
Resistance			60MΩ
Capacitance			100mF
Frequency	1kHz	1kHz	10MHz
Duty Cycle			•
Type K Temperature			
Diode			•
Continuity			•
Display Backlight	•	•	•
Work Light			•
Data Hold	•	•	•
NCV			•
MAX/MIN	•		•
Relative Measurement			•
Bar Graph	•		
DC Current (From Plug)			
Low Impedance			
Active Power	600kW	600kW	750kW
Apparent Power	600kVA	600kVA	750kVA
Reactive Power	600kVAr	600kVAr	750kVAr
Power Factor	0.3~1	0.3~1	0.3~1
Active Energy	9999kWh		
Harmonic Measurement		45~65Hz	45~65Hz
Data Logging	28 Groups	100 Groups	
Interface	RS232	RS232	Wireless
Certificate	CE	CE	CE/ETL

**ELECTRICAL TESTERS**

					
	CAT II CAT III CAT IV				
Model	MS6580B	MS8900	MS8900A	MS8900C	MS8902A
Page	64	65	66	67	68
Safety Rating	CAT II 1000V CAT III 600V	CAT II 1000V CAT III 600V	CAT II 1000V CAT III 600V	CAT II 1000V CAT III 600V	CAT II 1000V CAT III 600V
Non Contact Volatge	12~1000V	90~1000V	90~1000V	100~240V	12~1000V
Contact Volatge					
Frequency	50~60Hz	50~60Hz	50~60Hz	50~60Hz	50~500Hz
Resistance					
Metal Detecting					
RCD Test					
Work Light	•				
Sound & Light	•	•	•	•	•
Auto Power Off	•				•
Sensitivity adjustment	•				•
Infrared temperature	-20~330°C -4~626°F				
Certificate	CE/ETL	CE/ETL	CE/ETL	CE/ETL	CE/ETL

**ELECTRICAL TESTERS**

				
	CAT II CAT III CAT IV			
Model	MS8902B	MS8907	MS8922A	MS8922B
Page	68	69	70	71
Safety Rating	CAT II 1000V CAT III 600V	CAT II 1000V CAT III 600V	CAT III 600V	CAT III 400V
Non Contact Volatge	20~1000V	50~1000V		
Contact Volatge			400V	400V
Frequency	50~500Hz	50~60Hz	50~60Hz	50~60Hz
Resistance				
Metal Detecting	<20mm			
RCD Test		•		•
Work Light		•		
Sound & Light	•			
Auto Power Off	•			
Sensitivity adjustment	•			
Certificate	CE/ETL	CE/ETL	CE/ETL	CE/ETL

**CIRCUIT TESTERS**



	<p>CAT II CAT III CAT IV</p> 		
Model	MS5902RT	MS5905RT	MS6860
Page	74	75	76
Safety Rating	CAT II 600V	CAT II 600V	CAT II 230V
AC Voltage	230V/120V	230V	230V
Socket Test	•	•	•
GFCI Test	TF type	TF type	
RCD Test			
Work Light	•		
NCV		•	
Buzzer and LED Instruction	•	•	•
Certificate	CE/ETL	CE	CE/ETL

**CIRCUIT ANALYZERS**

	<p>CAT II CAT III CAT IV</p> 		
Model	MS5901	MS5908A	MS5908C
Page	78	79	80
Safety Rating	CAT III 600V	CAT III 300V	CAT III 600V
AC Voltage	400V	190V	375V
Frequency	400Hz	45~65Hz	45~65Hz
Motor & Phase Rotation Indicator	•		
Voltage Drop Current		12/15/20A	12/15/20A
Impedance measurement		•	•
GFCI Test		•	•
RCD Test		•	•
Data Hold		•	•
Backlight		•	•
Certificate	CE/ETL	CE/ETL	CE/ETL



**WIRE & CABLE TESTERS**

					
CAT II CAT III CAT IV					
Model	MS6810	MS6811	MS6812A	MS6813	MS6818
Page	82	83	84	85	86
Safety Rating					CAT III 300V
Auto Ranging					•
DC Voltage					12~400V
AC Voltage					12~400V
Frequency			300kHz	300kHz	125kHz
Low Battery Indicator		•			
Sensitivity Adjustable			•	•	•
Electric Wire			•	•	•
Coaxial Cable (BNC)	•			•	
Network Cable	•	•		•	
Telephone Wire			•	•	
Backlight					•
Worklight					•
Sound & light instructions			•	•	•
Certificate	CE/ETL	CE/ETL	CE/ETL	CE/ETL	CE/ETL

**EARTH RESISTANCE**

			
CAT II CAT III CAT IV			
Model	MS2302	MS2306	MS2308
Page	88	89	90
Safety Rating	CAT III 300V		
Resistance	4000Ω	20kΩ	20kΩ
Measurement Voltage	AC 200V	AC 20V/48V DC 20V	AC 20V/48V DC 20V
Sensing & Inducing Current Transformer			•
Back light	•	•	•
Interface			USB
Certificate	CE/ETL	CE/ETL	CE/ETL

## LCR METERS



Model	MS5308	MS6013	MS8910	MS8911	MY6243
Page	92	93	94	95	96
Auto Ranging			•	•	
Auto Power Off			•	•	
Resistance	20Ω/200MΩ		300Ω/30MΩ	60Ω/20MΩ	
Capacitance	200pF/20mF	200pF/20mF	3nF/30mF	600pF/6mF	2nF/200μF
Inductance	200μH~20kH			600μH/200H	2mH~2H
Diode			•		
Continuity Buzzer			•		
Auto Scanning			•	•	
Zero Adjustment		•			
LCR/DCR	•			•	
Data Hold	•		•	•	
Backlight	•				
Relative Measurement	•				
Interface	RS232				
Certificate	CE/ETL	CE/ETL	CE/ETL	CE/ETL	CE/ETL

## INSULATION TESTERS

CAT II  
CAT III  
CAT IV



Model	MS5203	MS5205	MS5215
Page	98	99	100
Safety Rating	CAT III 1000V CAT IV 600V	CAT III 1000V CAT IV 600V	CAT III 1000V CAT IV 600V
Insulation Resistance	0.01MΩ~10GΩ	0.01MΩ~10GΩ	0.01MΩ~5TΩ
Output Voltage	1kV DC	2.5kV DC	5kV DC
Leakage Current test			1nA~3mA
Continuity Test	0.01Ω~200Ω (1mA)	0.01Ω~200Ω (1mA)	
Measurement Voltage	DC 1000V AC 700V	DC 1000V AC 700V	DC 1000V AC 750V
Short Current	1.8mA	3mA	3mA
Temperature Test			-10~70°C
Back Light	•	•	•
Interface			USB
Certificate	CE/ETL	CE/ETL	CE/ETL

**DIGITAL THERMOMETERS**



Model	MS6500	MS6505	MS6511	MS6512	MS6513	MS6514
Page	104	105	106	107	108	109
Thermocouple Type	K		K.J.T.E	K.J.T.E	K.J.T.E. R.S.N	K.J.T.E. R.S.N
Temperature	-50~750°C -58~1382°F	-20~60°C -4~140°F	-200~1372°C -328~2501°F	-200~1372°C -328~2501°F	-200~1372°C -328~2501°F	-200~1372°C -328~2501°F
Injection Method	Single		Single	Dual	Single	Dual
Channel			TC	T1/T2/T1-T2	TC	T1/T2/T1-T2
Relative Humidity		0~100%				
Update Rate	500mS					
Clock		•				
MAX/MIN/AVG/DIF		MAX/MIN	•	•	•	•
Date Logging		16300 groups			1000 groups	1000 groups
Backlight		•				
Date Hold	•	•	•	•	•	•
Interface		RS232			USB	USB
Certificate	CE	CE	CE	CE	CE	CE

**INFRARED THERMOMETERS**



Model	MS6522A	MS6522B	MS6531B	MS6531C	MS6541
Page	110	111	112	113	114
Color Display			•	•	•
IRT Temperature	-20~300°C -4~572°F	-20~500°C -4~932°F	-40~800°C -40~1472°F	-40~800°C -40~1472°F	-50~760°C -58~1400°F
Type K Temperature				-40~1080°C -40~1976°F	-50~300°C -58~572°F
Distance to Spot(D:S)	10:1	10:1	12:1	12:1	30:1
Emissivity	0.95	0.95	0.1~0.99	0.1~0.99	0.1~0.99
MAX/MIN/AVG/DIF	MAX/MIN/AVG	MAX/MIN/AVG	•	•	•
Data Logging				20 groups	100 groups
Backlight	•	•	•	•	•
Data hold	•	•	•	•	•
Certificate	CE	CE/ETL	CE/ETL	CE/ETL	CE

**SOUND METERS**



Model	MS6700	MS6701	MS6708
Page	116	117	118
Display	2000	2000	2000
Auto Ranging	•	•	•
Auto Power Off	•	•	•
Sound Level	30~130dB	30~130dB	30~130dB
Dynamic	50dB	50dB	50dB
Frequency	30Hz~8kHz	30Hz~8kHz	30Hz~8kHz
A/C Weighting	•	•	•
Data Logging		16000	
Data Hold			•
Date/Time	•	•	
Backlight	•	•	•
MAX	•	•	•
AC adapter	•	•	
AC/DC Signal output	•	•	
Interface		RS232/USB	
Certificate	CE	CE/ETL	CE/ETL

**MOISTURE METERS**



Model	MS6900	MS6900A
Page	119	120
Ranging	Wood , Brick, Plaster ...	
Testing Depth	50mm	50mm
Object moisture	0~60%	0~60%
Ambient TEMP	-10~50°C/14~122°F	
Sampling Rate	240mS	240mS
MAX/MIN	•	•
Unit Selection	WB, TD, °C, °F, %RH	
Auxiliary Verification		•
Data Hold	•	•
Backlight	•	•
Certificate	CE	CE

**TACHOMETERS**



Model	MS6208A	MS6208B
Page	121	122
Contact	50~19999	
Non-Contact measurement		50~99999RPM
Measuring Distance		50~250mm
Auto Power Off	•	•
MAX/MIN	•	•
Data Hold	•	•
Backlight	•	•
Unit Selection	•	
Data Logging	100 Groups	100 Groups
Certificate	CE/ETL	CE/ETL

**ANEMOMETER**



Model	MS6252A	MS6252B	MS6252D
Page	123	124	125
m/s (meter per second)	0.8~40 m/s	0.8~40 m/s	0.8~40 m/s
km/h (kilometer per hour)	2.88~144 km/h	2.88~144 km/h	2.88~144 km/h
ft/s (feet per second)	2.62~131.2 ft/s	2.62~131.2 ft/s	2.62~131.2 ft/s
Knots (nautical miles per hour)	1.6~77.70 Knots	1.6~77.70 Knots	1.6~77.70 Knots
mile/h (mile per hour)	1.8~90.00 mile/h	1.8~90.00 mile/h	1.8~90.00 mile/h
ft/m (feet per minute)	157.5~7874 ft/m	157.5~7874 ft/m	157.5~7874 ft/m
Temperature		-10~60°C	-10~60°C
Relative Humidity		20~80%RH	20~80%RH
Ambient		•	•
Dew point		•	•
Wet Bulb		•	•
Interface		USB	Wireless
Certificate	CE/ETL	CE/ETL	CE/ETL

**GAS DETECTOR**



Model	MS6310
Page	126
Alarm at level	10%~40%
Response Time	2 seconds
Warm up time	2 Minutes
Easy to Identify	•
Pinpoint Gas Leaks	•
Portable	•
High Sensitivity	•
Resume Original measurement	State after 7~10 min in clear air
Gas Detected	Natural gas, Methane, Ethane, Propane
Certificate	CE

**PAT TESTER**

CAT II  
CAT III  
CAT IV



Model	MS5911
Page	102
Safety Rating	CAT II 300V
Grounding	20Ω
Insulation Resistance	20MΩ
leakage Current	10.5mA
Cord Test	•
Polarity Test	•
Power Socket Test	•
Auto Power Off	•
Data HoldBacklight	•
Data logging	300 groups
Certificate	CE/ETL

**LIGHT METERS**



Model	MS6610	MS6612	MS6612B	MS6612D
Page	127	128	129	130
Auto Ranging		•	•	•
Auto Power Off		•	•	•
Display Counts	2000	2000	2000	2000
Ranging.	50000Lux	200000Lux 20000FC	200000Lux 20000FC 999900CD	200000Lux 20000FC 999900CD
Unit Selection	Lux	Lux/FC	Lux/FC/CD	Lux/FC/CD
Relative		•	•	•
Peak		•	•	•
MAX/MIN		•	•	•
Data Hold	•	•	•	•
Bar Graph		•	•	•
LED light source			•	•
Interface				Wireless
Certificate	CE/ETL	CE/ETL	CE/ETL	CE/ETL

**STUD METAL DETECTOR**



Model	MS6906
Page	131
Auto Power Off	•
Wooden Pillar	30mm
Metal Stud Detection Detph	30/50mm
AC Voltage Detection Detph	75mm
Data Hold	•
Backlight	•
Certificate	CE/ETL

**PROCESS CALIBRATOR**



Model	MS7221
Page	132
DC Volatge	100mV/10V
AC Voltage	
DC Current	0~24mA
AC Current	
Certificate	CE/ETL

**ENVIRONMENT TESTER**



Model	MS6300
Page	133
Auto Ranging	•
Auto Power Off	•
Temperature	-10~60°C
Humidity	20~80%RH
Sound level	30~130dB
luminance	50000Lux
Wind Speed	0.5~20m/s, 1.8~72km/h 100~4000FPM, 0.9~38.9Knots
AirFlow [CMM]	0~999900
AirFlow [CFM]	0~999900
A/C Weighting	•
MAX/MIN/AVG/DIF	•
Data Hold	•
Backlight	•
Certificate	CE/ETL

# DIGITAL MULTIMETERS

MANUAL RANGE | AUTO RANGE | POCKET & PEN TYPE  
BENCH TYPE | SPECIAL APPLICATION







**MAIN APPLICATIONS**



DOMESTIC

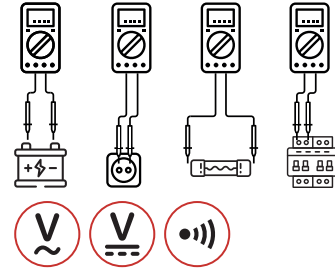

ELECTRONICS

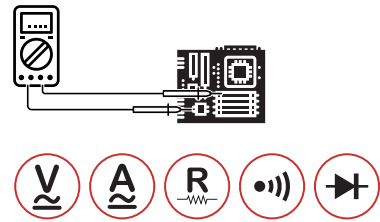

DIGITAL MULTIMETER

**MS8301A**

SKU NO: MS8301ACBGLO  
 UPC CODE: 810053675540  
 EAN CODE: 8435394784298

**FEATURE**

- Display 2000 Counts.
- Data hold.
- Battery Tester 1.5V/9V.

**SPECIFICATIONS**

AC Voltage <b>600V</b>	DC Voltage <b>600V</b>	DC Current <b>10A</b>
Resistance <b>2MΩ</b>	Display Counts <b>2000</b>	Continuity test <b>&lt;30Ω</b>

**CONTENTS**



145×60×188mm  
 5.7"×2.4"×7.4"  
 220g/0.48lb



2×1.5V AAA  
 Batteries



ACCESSORIES

Test leads/Multi-Function  
 Socket/Battery/



Calibration  
 Certificate



Quick  
 Start Guide

**PACKAGING INFORMATION**



Color Box  
 L145×W60×H188mm



Carton Box  
 40×32×31.5cm



X 20PCS



**MAIN APPLICATIONS**



DOMESTIC

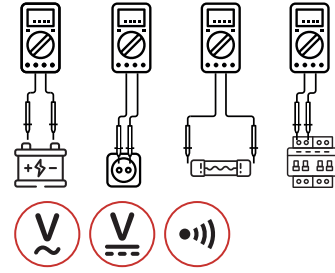

ELECTRONICS

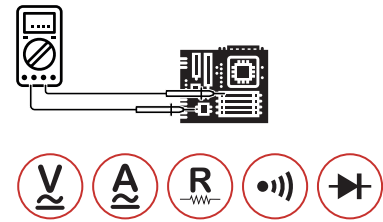

DIGITAL MULTIMETER

**MS8301B**

SKU NO: MS8301BCBGLO  
 UPC CODE: 810053676769  
 EAN CODE: 8435394785295

**FEATURE**

- Display 4000 Counts.
- Back Light.
- Non-contact Voltage Detector.

**SPECIFICATIONS**

AC Voltage <b>600V</b>	DC Voltage <b>600V</b>	DC Current <b>10A</b>
Display Counts <b>4000</b>	Resistance <b>40MΩ</b>	Continuity test <b>&lt;50Ω</b>
Capacitance <b>100μF</b>	Frequency <b>100kHz</b>	

**CONTENTS**



145×60×188mm  
 5.7"×2.4"×7.4"  
 220g/0.48lb



3×1.5V AAA  
 Batteries



ACCESSORIES

Test leads/Multi-Function  
 Socket/Battery/



Calibration  
 Certificate



Quick  
 Start Guide

**PACKAGING INFORMATION**



Color Box  
 L145×W60×H188mm



Carton Box  
 40×32×31.5cm



X 20PCS



DIGITAL MULTIMETER  
**MY70**

SKU NO: MY70CBGLO  
UPC CODE: 810053672280  
EAN CODE: 8435394778006

**FEATURE**

- Auto Power Off.
- Transistor hFE 0~1000.
- Diode Open Voltage 3.0V.
- Data Hold.

**SPECIFICATIONS**

AC Voltage <b>600V</b>	DC Voltage <b>600V</b>	AC Current <b>10A</b>
DC Current <b>10A</b>	Resistance <b>200MΩ</b>	Continuity <b>&lt;50Ω</b>
Display Counts <b>2000</b>		

**MAIN APPLICATIONS**

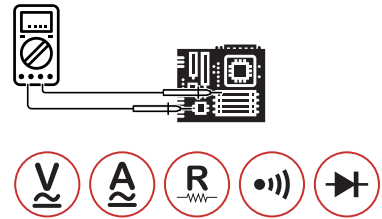
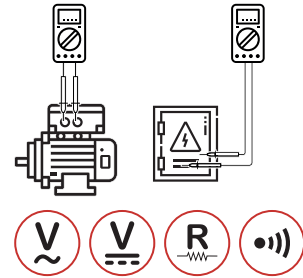
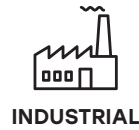
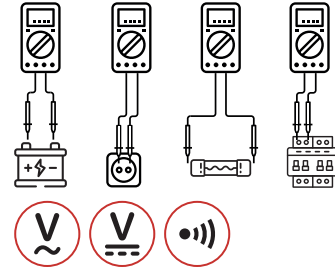

**CONTENTS**



188×93×50mm  
7.4"×3.7"×1.96"  
380g/0.84lb



1×9V 6F22  
Battery



ACCESSORIES

Test Leads/Multi-Function Socket/  
Battery



Calibration  
Certificate



Quick  
Start Guide

**PACKAGING INFORMATION**



**Color Box**  
L165×W70×H225mm



**Carton Box**  
47×37.5×35.5cm



**X 20PCS**



**MAIN APPLICATIONS**

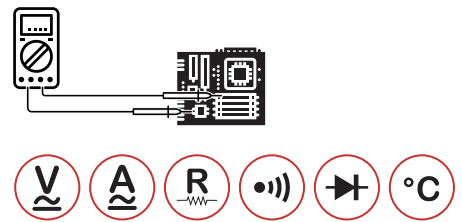
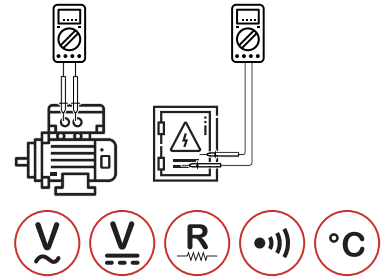
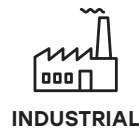
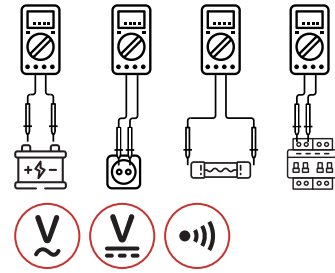

**DIGITAL MULTIMETER**  
**MY74**

SKU NO: MY74CBGLO  
UPC CODE: 810053672297  
EAN CODE: 8435394778013

**FEATURE**

- Auto Power Off.
- Transistor hFE 0~1000.
- Diode Open Voltage 3.0V.
- Data Hold.

**SPECIFICATIONS**

AC Voltage <b>600V</b>	DC Voltage <b>600V</b>	AC Current <b>10A</b>
DC Current <b>10A</b>	Resistance <b>200MΩ</b>	Capacitance <b>100μF</b>
Frequency <b>20kHz</b>	Continuity <b>&lt;50Ω</b>	Display Counts <b>2000</b>
Temperature <b>-20~1000°C</b>		

**CONTENTS**



188×93×50mm  
7.4"×3.7"×1.96"  
380g/0.84lb



1×9V 6F22  
Battery



ACCESSORIES

Test Leads/K type thermocouple/  
Multi-Function Socket/Battery



Calibration  
Certificate



Quick  
Start Guide

**PACKAGING INFORMATION**



**Color Box**  
L165×W70×H225mm



**Carton Box**  
47×37.5×35.5cm



**X 20PCS**



## DIGITAL MULTIMETER MY75

SKU NO: MY75CBGLO  
UPC CODE: 810053672303  
EAN CODE: 8435394778020

### FEATURE

- Diode Open Voltage 3.0V.
- Transistor hFE 0~1000 .
- Data Hold.
- Auto Power Off.

### SPECIFICATIONS

AC Voltage <b>600V</b>	DC Voltage <b>600V</b>	AC Current <b>10A</b>
DC Current <b>10A</b>	Resistance <b>200MΩ</b>	Capacitance <b>200nF</b>
Frequency <b>20kHz</b>	Continuity <b>&lt;60Ω</b>	Display Counts <b>20000</b>

### MAIN APPLICATIONS



DOMESTIC

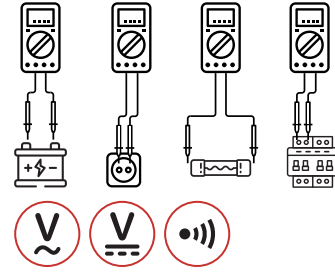

INDUSTRIAL

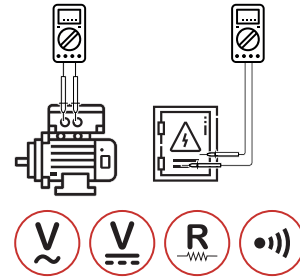

ELECTRONICS

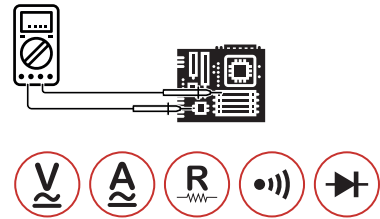

### CONTENTS



188×93×50mm  
7.4"×3.7"×1.96"  
380g/0.84lb



1×9V 6F22  
Battery



ACCESSORIES

Test Leads/Multi-Function Socket/  
Battery



Calibration  
Certificate



Quick  
Start Guide

### PACKAGING INFORMATION



**Color Box**  
L165×W70×H225mm



**Carton Box**  
47×37.5×35.5cm



**X 20PCS**



# DIGITAL MULTIMETER WITH WIRELESS MS8238H

SKU NO: MS8238HCBGLO  
UPC CODE: 810053675335  
EAN CODE: 8435394783383

## FEATURE

- Auto Power Off.
- True RMS For AC Voltage & AC Current.
- Wireless APP connection.
- Non-Contact Voltage Detector.

## SPECIFICATIONS

AC Voltage <b>600V</b>	DC Voltage <b>600V</b>	AC Current <b>10A</b>
DC Current <b>10A</b>	Resistance <b>40MΩ</b>	Continuity <b>&lt;50Ω</b>
Display Counts <b>4000</b>	Temperature <b>-20~1000°C/-4~1832°F</b>	

## MAIN APPLICATIONS

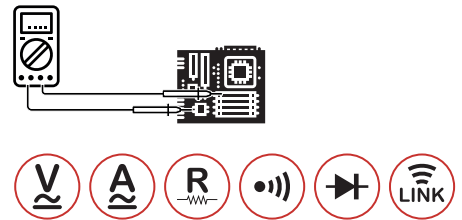
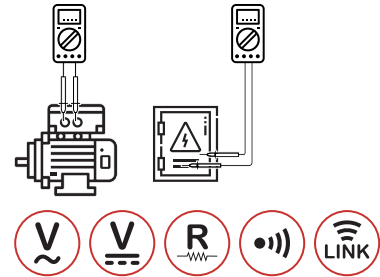
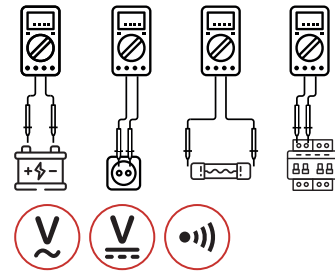

## CONTENTS



148×73.5×50mm  
5.8"×2.9"×1.96"  
241g/0.53lb



1x9V 6F22  
Battery



ACCESSORIES

Test Leads/K Type Thermocouple/  
Battery



Calibration  
Certificate



Quick  
Start Guide

## PACKAGING INFORMATION



**Color Box**  
L145×W60×H188mm



**Carton Box**  
40×32×31.5cm



**X 20PCS**



## DIGITAL MULTIMETER MS8251A

SKU NO: MS8251ACBGLO  
UPC CODE: 810053673157  
EAN CODE: 8435394778884

### FEATURE

- Auto & Manual Ranging.
- Auto Power Off.
- True RMS.
- Non-Contact Voltage Detector.

### SPECIFICATIONS

AC Voltage <b>1000V</b>	DC Voltage <b>1000V</b>	AC Current <b>10A</b>
DC Current <b>10A</b>	Resistance <b>66MΩ</b>	Continuity <b>&lt;50±20Ω</b>
Capacitance <b>66mF</b>	Frequency <b>66MHz</b>	Display Counts <b>6600</b>

### MAIN APPLICATIONS

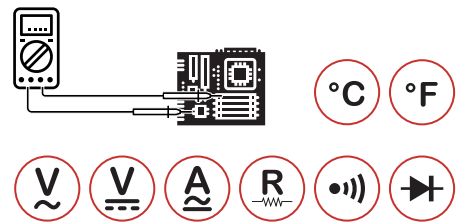
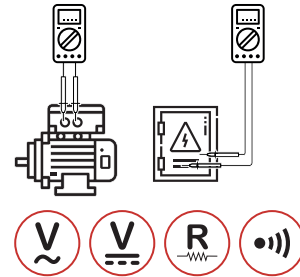
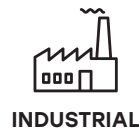
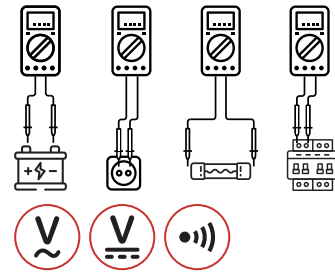

### CONTENTS



175×85×52mm  
6.89"×3.3"×2.1"  
420g/0.92lb



1×9V 6F22  
Battery



**ACCESSORIES**

Test leads/K type thermocouple/  
Multi-Function Socket/Carry bag/Battery



Calibration  
Certificate



Quick  
Start Guide

### PACKAGING INFORMATION



**Color Box**  
L165×W70×H225mm



**Carton Box**  
47×37.5×35.5cm



**X 20PCS**



**MAIN APPLICATIONS**

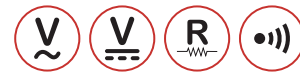
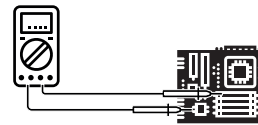
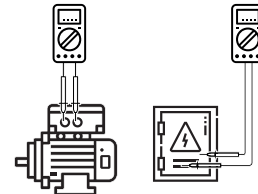
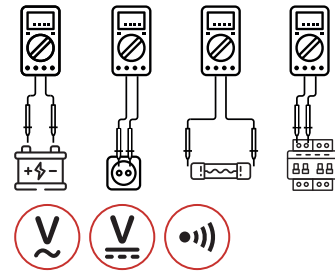

SMART DIGITAL MULTIMETER  
**MS8301D**

SKU NO: MS8301DCBGLO  
UPC CODE: 810053672273  
EAN CODE: 8435394777993

**FEATURE**

- Auto Ranging.
- Auto Power Off.
- Dual Display.
- Continuity Buzzer.

**SPECIFICATIONS**

AC Voltage <b>600V</b>	DC Voltage <b>600V</b>	Resistance <b>10MΩ</b>
Frequency <b>3kHz</b>	Continuity <b>&lt;40Ω</b>	Display Counts <b>6000</b>

**CONTENTS**



150×74×48mm  
5.9"×2.9"×1.7"  
220g/0.48lb



2×1.5V AAA Batteries



ACCESSORIES

Test leads/  
Battery



Calibration  
Certificate



Quick  
Start Guide

**PACKAGING INFORMATION**



**Color Box**  
L145×W60×H188mm



**Carton Box**  
40×32×31.5cm



**X 20PCS**





**MAIN APPLICATIONS**

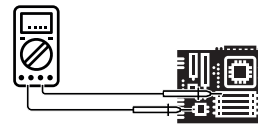
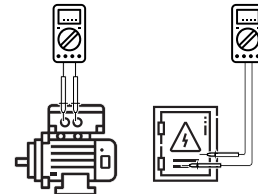
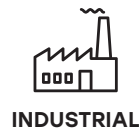
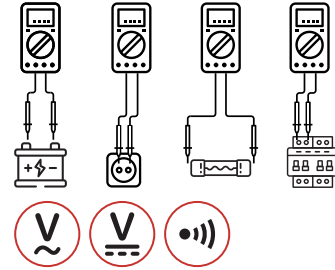

DIGITAL MULTIMETER  
**MS8332C**

SKU NO: MS8332CCBGLO  
UPC CODE: 810053674857  
EAN CODE: 8435394782065

**FEATURE**

- Display 4000 Counts.
- Diode Open Voltage 1.5v.
- Low Battery Display.

**SPECIFICATIONS**

AC Voltage <b>600V</b>	DC Voltage <b>600V</b>	AC Current <b>400mA</b>
DC Current <b>400mA</b>	Resistance <b>400MΩ</b>	Continuity <b>&lt;50±20Ω</b>
Capacitance <b>100μF</b>	Frequency <b>5mHz</b>	Display Counts <b>4000</b>

**CONTENTS**



110×58×33mm  
4.4"×2.3"×1.3"  
150g/0.25lb



2×1.5V AAA Batteries



ACCESSORIES

Test leads/Multi-Function Socket/  
Battery



Calibration  
Certificate



Quick  
Start Guide

**PACKAGING INFORMATION**



**Color Box**  
L145×W60×H188mm



**Carton Box**  
40×32×31.5cm



**X 20PCS**



**MAIN APPLICATIONS**

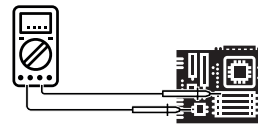
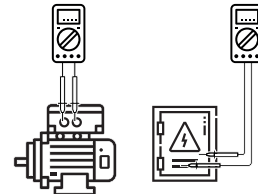
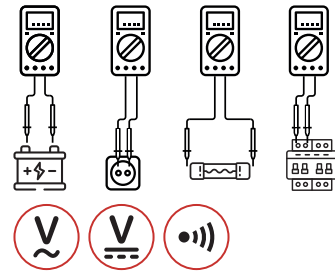

**DIGITAL MULTIMETER**  
**MS8340A**

SKU NO: MS8340ACBGLO  
UPC CODE: 810053675359  
EAN CODE: 8435394783000

**FEATURE**

- Auto & Manual Ranging.
- Auto Power Off.
- Relative Measurement.
- Low Pass Filter 1kHz.

**SPECIFICATIONS**

AC Voltage <b>750V</b>	DC Voltage <b>1000V</b>	AC Current <b>10A</b>
DC Current <b>10A</b>	Resistance <b>60MΩ</b>	Continuity <b>&lt;50±20Ω</b>
Capacitance <b>400μF</b>	Frequency <b>10MHz</b>	Display Counts <b>6000</b>

**CONTENTS**



205x102x58mm  
8.1"x4.0"x2.2"  
390g/0.86lb



4x1.5V AA Batteries



ACCESSORIES

Test leads/K type thermocouple/  
Multi-Function Socket/Battery



Calibration Certificate



Quick Start Guide

**PACKAGING INFORMATION**



**Color Box**  
L173xW85xH235mm



**Carton Box**  
49x45x37.2cm



**X 20PCS**



# DIGITAL MULTIMETER WITH WIRELESS MS8361D

SKU NO: MS8361DCBGLO  
UPC CODE: 810053675366  
EAN CODE: 8435394783406

## FEATURE

- Auto & Manual Ranging.
- Auto Power Off.
- True RMS For AC Voltage & AC Current.
- Wireless APP connection.

## SPECIFICATIONS

AC Voltage <b>600V</b>	DC Voltage <b>600V</b>	AC Current <b>10A</b>
DC Current <b>10A</b>	Resistance <b>40MΩ</b>	Continuity <b>&lt;50Ω</b>
Capacitance <b>99.99mF</b>	Display Counts <b>4000</b>	

## MAIN APPLICATIONS

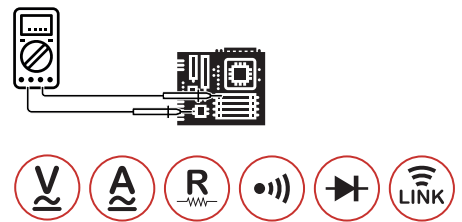
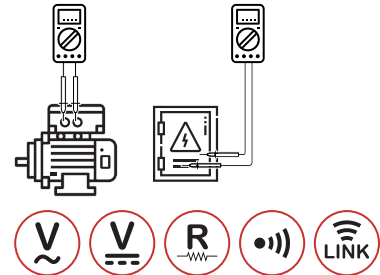
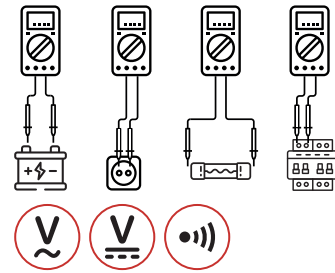

## CONTENTS



188×92×50mm  
7.4"×3.6"×2.0"  
380g/0.83lb



1×9V 6F22  
Battery



ACCESSORIES

Test Leads/Multi-Function Socket/  
Battery



Calibration  
Certificate



Quick  
Start Guide

## PACKAGING INFORMATION



**Color Box**  
L165×W70×H225mm



**Carton Box**  
47×37.5×35.5cm



**X 20PCS**



**MAIN APPLICATIONS**

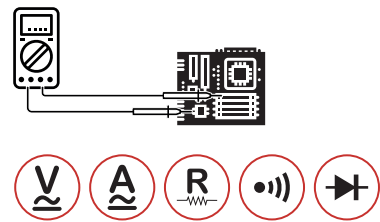
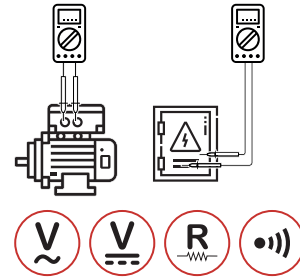
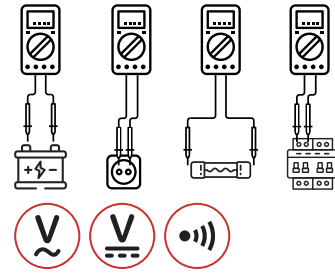

**DIGITAL MULTIMETER**  
**MY78**

SKU NO: MY78CBGLO  
UPC CODE: 810053674550  
EAN CODE: 8435394779621

**FEATURE**

- Auto & Manual Ranging.
- Relative Measurement.
- Diode Open Voltage 1.5V.
- Transistor hFE 0~1000.

**SPECIFICATIONS**

AC Voltage <b>600V</b>	DC Voltage <b>600V</b>	AC Current <b>10A</b>
DC Current <b>10A</b>	Resistance <b>40MΩ</b>	Capacitance <b>200μF</b>
Frequency <b>&gt;200kHz</b>	Continuity <b>&lt;50±20Ω</b>	Display Counts <b>4000</b>

**CONTENTS**



188×91×31.5mm  
7.67"×3.6"×1.24"  
420g/0.92lb



1×9V 6F22  
Battery



ACCESSORIES

Test Leads/Multi-Function Socket/  
Battery



Calibration  
Certificate



Quick  
Start Guide

**PACKAGING INFORMATION**



**Color Box**  
L165×W70×H225mm



**Carton Box**  
47×37.5×35.5cm



**X 20PCS**



**MAIN APPLICATIONS**



DOMESTIC

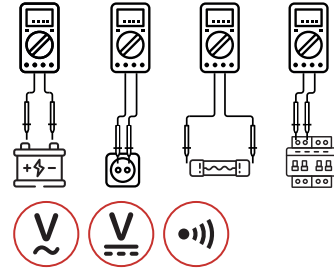

ELECTRONICS

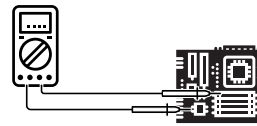

POCKET DIGITAL MULTIMETER  
**MS8333A**

SKU NO: MS8333ACBGLO  
UPC CODE: 810053674482  
EAN CODE: 8435394779553

**FEATURE**

- Auto Ranging.
- Auto Power Off.
- True RMS For AC Voltage & AC Current.
- Non-Contact Voltage Detector.

**SPECIFICATIONS**

AC Voltage <b>600V</b>	DC Voltage <b>600V</b>	AC Current <b>600mA</b>
DC Current <b>600mA</b>	Resistance <b>60MΩ</b>	Continuity <b>&lt;50±20Ω</b>
Capacitance <b>600uF</b>	Frequency <b>10kHz</b>	Display Counts <b>6000</b>

**CONTENTS**



122×62×44mm  
4.8"×2.44"×1.73"  
186g/0.4lb



2×1.5V AAA  
Batteries



Battery

ACCESSORIES



Calibration  
Certificate



Quick  
Start Guide

**PACKAGING INFORMATION**



Color Box  
L145×W60×H188mm



Carton Box  
40×32×31.5cm



X 20PCS



**PEN-TYPE DIGITAL MULTIMETER**  
**MS8211**

SKU NO: MS8211CBGLO  
UPC CODE: 810053673010  
EAN CODE: 8435394778976

**FEATURE**

- Auto & Manual Ranging.
- Auto Power Off.
- Diode Open Voltage 1.5V.
- Maximum Value Hold.

**SPECIFICATIONS**

AC Voltage <b>600V</b>	DC Voltage <b>600V</b>	Resistance <b>20MΩ</b>
Continuity <b>&lt;50±20Ω</b>	Display Counts <b>2000</b>	

**MAIN APPLICATIONS**



DOMESTIC

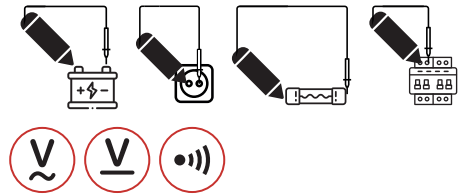

ELECTRONICS

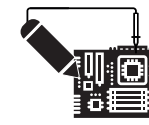

**CONTENTS**



208×38×29mm  
8.26"×1.5"×1.1"  
110g/0.24lb



2×1.5V AAA  
Batteries



ACCESSORIES

Test leads/Alligator Clips/  
Battery



Calibration  
Certificate



Quick  
Start Guide

**PACKAGING INFORMATION**



**Color Box**  
L85×W45×H220mm



**Carton Box**  
46×26×36cm



**X 40PCS**



**PEN-TYPE DIGITAL MULTIMETER**  
**MS8211D**

SKU NO: MS8211DCBGLO  
UPC CODE: 810053672655  
EAN CODE: 8435394778747

**FEATURE**

- Auto & Manual Ranging.
- Auto Power Off.
- Diode Open Voltage 1.5V.
- Maximum Value Hold.

**SPECIFICATIONS**

AC Voltage <b>600V</b>	DC Voltage <b>600V</b>	AC Current <b>200mA</b>
DC Current <b>200mA</b>	Resistance <b>20MΩ</b>	Continuity <b>&lt;50±20Ω</b>
Display Counts <b>2000</b>		

**MAIN APPLICATIONS**



DOMESTIC

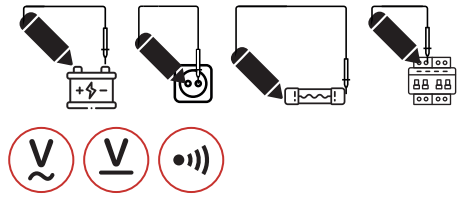

ELECTRONICS

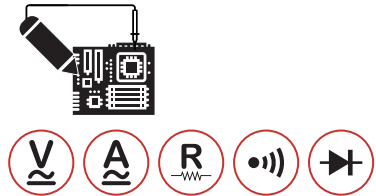

**CONTENTS**



208×38×29mm  
8.26"×1.5"×1.1"  
110g/0.24lb



2×1.5V AAA  
Batteries



ACCESSORIES

Test leads/Alligator Clips/  
Battery



Calibration  
Certificate



Quick  
Start Guide

**PACKAGING INFORMATION**



Color Box  
L85×W45×H220mm



Carton Box  
46×26×36cm



X 40PCS



**PEN-TYPE DIGITAL MULTIMETER**  
**MS8212A**

SKU NO: MS8212ACBGLO  
UPC CODE: 810053673034  
EAN CODE: 8435394778761

**FEATURE**

- Auto & Manual Ranging.
- Auto Power Off.
- Diode Open Voltage 1.5V.
- Maximum Value Hold.

**SPECIFICATIONS**

AC Voltage <b>600V</b>	DC Voltage <b>600V</b>	AC Current <b>200mA</b>
DC Current <b>200mA</b>	Resistance <b>20MΩ</b>	Continuity <b>&lt;50±20Ω</b>
Display Counts <b>2000</b>		

**MAIN APPLICATIONS**

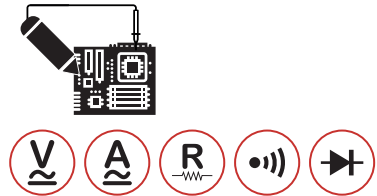
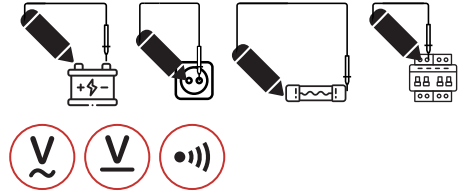

**CONTENTS**

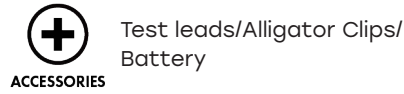
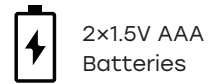
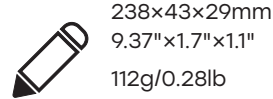

**PACKAGING INFORMATION**

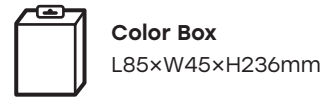





**MULTI-FUNCTION DIGITAL COUNTER**  
**MS6100**

SKU NO: MS6100CBGLO  
UPC CODE: 810053675199  
EAN CODE: 8435394783185

**FEATURE**

- Operating Temperature 0°C~40°C.
- Storage Temperature -10°C~50°C.
- Relative Humidity 20%~80%RH (0°C~40°C).
- Data Hold.

**SPECIFICATIONS**

A Input <b>10~100MHz</b>	B Input <b>100~1300MHz</b>	Display Counts <b>2200</b>
-----------------------------	-------------------------------	-------------------------------

**MAIN APPLICATIONS**

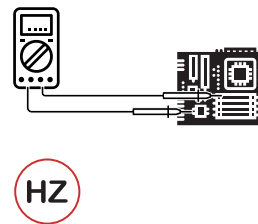
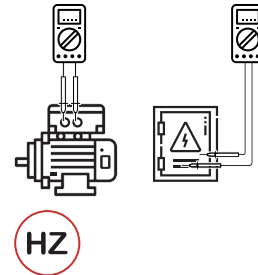
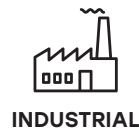
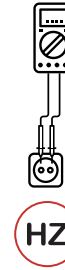

**CONTENTS**

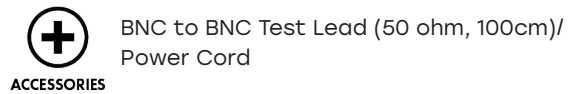
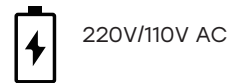
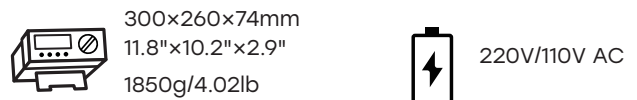

**PACKAGING INFORMATION**

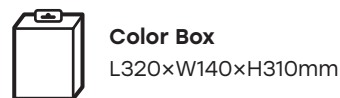



TRUE RMS BENCHTOP MULTIMETER  
**MS8040**

SKU NO: MS8040CBGLO  
UPC CODE: 810053672631  
EAN CODE: 8435394778273

**FEATURE**

- Auto & Manual Ranging.
- True RMS for AC Voltage & AC Current.
- Low Pass Filter (1kHz) for AC Voltage & AC Current.

**SPECIFICATIONS**

AC Voltage <b>750V</b>	DC Voltage <b>1000V</b>	AC Current <b>10A</b>
DC Current <b>10A</b>	Resistance <b>200MΩ</b>	Capacitance <b>20mF</b>
Display Counts <b>22000</b>		

**MAIN APPLICATIONS**

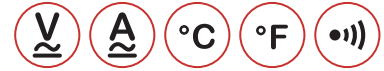
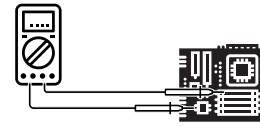

**CONTENTS**

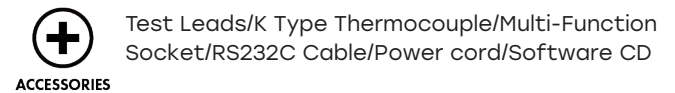
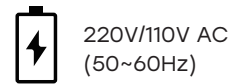
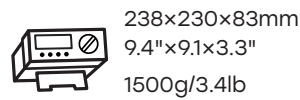

**PACKAGING INFORMATION**

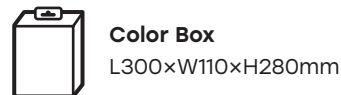



TRUE RMS BENCHTOP MULTIMETER  
**MS8050**

SKU NO: MS8050CBGLO  
UPC CODE: 810053674390  
EAN CODE: 8435394779461

**FEATURE**

- True RMS.
- dBm Measurement.
- Relative Measurement.
- Diode Open Voltage 3.3V.

**SPECIFICATIONS**

AC Voltage <b>100 0V</b>	DC Voltage <b>1000V</b>	AC Current <b>10A</b>
DC Current <b>10A</b>	Resistance <b>50MΩ</b>	Capacitance <b>5000μF</b>
Display Counts <b>53000</b>		

**MAIN APPLICATIONS**

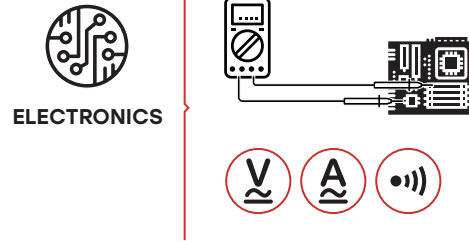

**CONTENTS**

- 350×240×100mm  
13.8"×9.5"×3.9"  
2500g/5.5lb
- 220V/110V AC
- Test leads/Alligator clip/Power cord/RS232C cable/  
Software CD/Carrying strap
- ACCESSORIES
- Calibration Certificate
- QSG Quick Start Guide

**PACKAGING INFORMATION**

- Color Box**  
L465×W140×H320mm
- Carton Box**  
48.5×30×35cm
- X 2PCS**



## DIGITAL INSULATION MULTIMETER MS5208

SKU NO: MS5208CBGLO  
UPC CODE: 810053673065  
EAN CODE: 8435394778792

### FEATURE

- Auto & Manual Ranging.
- Auto Power Off.
- True RMS For AC Voltage & AC Current.
- DAR/PI Mod.

### SPECIFICATIONS

AC Voltage <b>750V</b>	DC Voltage <b>1000V</b>	AC Current <b>400mA</b>
DC Current <b>400mA</b>	DC Output <b>1000V</b>	Resistance <b>66Ω</b>
Capacitance <b>66mF</b>	Frequency <b>10kHz</b>	Continuity <b>&lt;30Ω</b>
Display Counts <b>6600</b>	Temperature <b>-30~1000°C / -22~2372°F</b>	

### MAIN APPLICATIONS

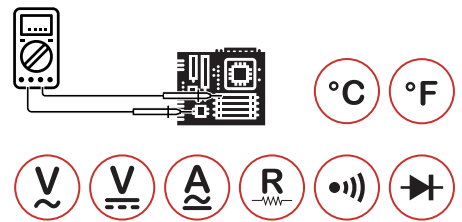
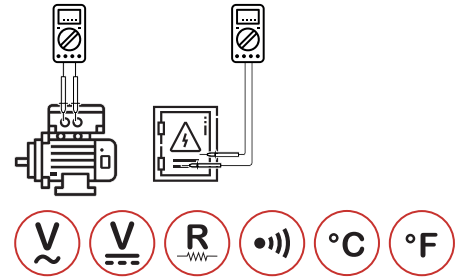
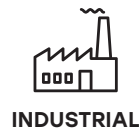
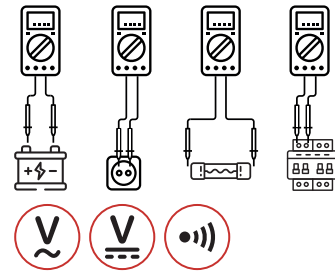

### CONTENTS



205x102x58mm  
8.1"x4.0"x2.3"  
390g/0.86lb



4x1.5V AA  
Batteries



ACCESSORIES

Test Leads/Test Clips/K Type Thermocouple/  
Multi-Function Socket/Carry Bag/Battery



Calibration  
Certificate



Quick  
Start Guide

### PACKAGING INFORMATION



**Color Box**  
L172xW80xH255mm



**Carton Box**  
53x44.5x37cm



**X 20PCS**



**MAIN APPLICATIONS**

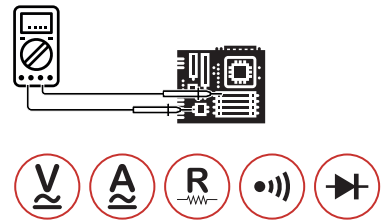
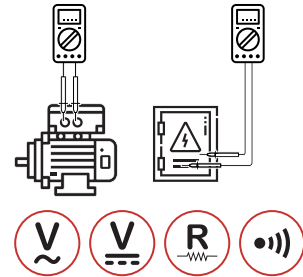
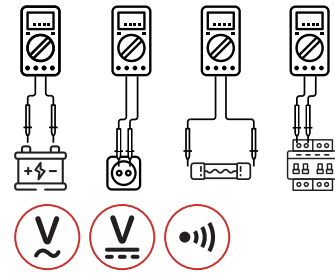

**DIGITAL MULTIMETER (ENGINE ANALYZER)**  
**MS8239D**

SKU NO: MS8239DCBGLO  
UPC CODE: 810053672983  
EAN CODE: 8435394778716

**FEATURE**

- Auto & Manual Ranging.
- Auto Power Off.
- Diode Open Voltage 2.7V.
- Maximum Measurement.

**SPECIFICATIONS**

AC Voltage <b>600V</b>	DC Voltage <b>600V</b>	AC Current <b>10A</b>
DC Current <b>10A</b>	Resistance <b>20MΩ</b>	Continuity <b>&lt;50Ω</b>
Display Counts <b>2000</b>		

**CONTENTS**



150×74×41mm  
5.9"×2.9"×1.6"  
202g/0.44lb



2×1.5V AAA Batteries



**ACCESSORIES**

Test Leads/  
Battery



Calibration  
Certificate



Quick  
Start Guide

**PACKAGING INFORMATION**



**Color Box**  
L145×W60×H188mm



**Carton Box**  
40×32×31.5cm



**X 20PCS**

# DIGITAL CLAMP METERS

AC CURRENT | AC/DC CURRENT | SPECIAL APPLICATION  
LEAKAGE | POWER





**MAIN APPLICATIONS**

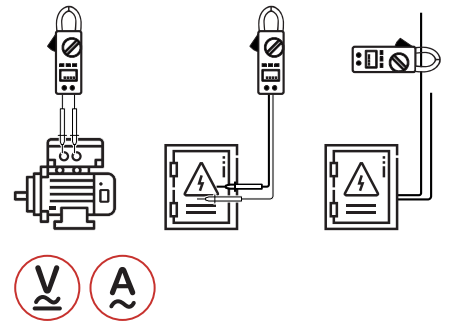
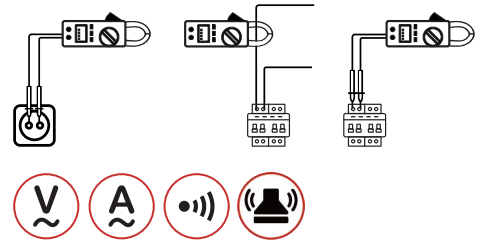

**DIGITAL AC CLAMP METER**  
**MS2009A**

SKU NO: MS2009ACBGLO  
UPC CODE: 810053672549  
EAN CODE: 8435394778181

**FEATURE**

- Auto & Manual Ranging.
- Auto Power Off.
- Non-Contact Voltage Detector.
- Diode Open Volatge 1.5V.

**SPECIFICATIONS**

AC Voltage <b>600V</b>	DC Voltage <b>600V</b>	AC Current <b>600A</b>
Resistance <b>20MΩ</b>	Display Counts <b>2000</b>	Jaw Opening <b>26mm/1.0"</b>
Continuity <b>&lt;60Ω</b>		

**CONTENTS**



218×78×35mm  
8.9"×3.1"×1.4"  
239g/0.53lb



3×1.5V AAA  
Batteries



**ACCESSORIES**

Test Leads/Carry bag/  
Battery



Calibration  
Certificate



Quick  
Start Guide

**PACKAGING INFORMATION**



**Color Box**  
L188xW145xH60mm



**Carton Box**  
50×30.5×23cm



**X 40PCS**



**MAIN APPLICATIONS**

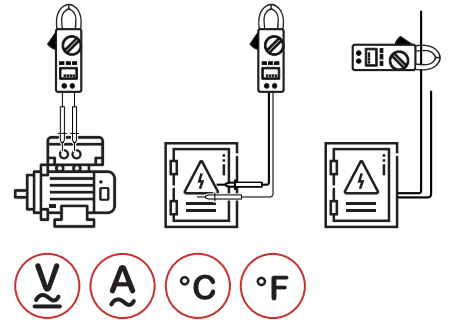
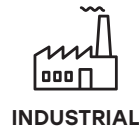
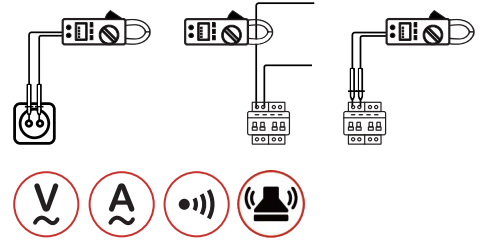

**DIGITAL AC CLAMP METER**  
**MS2009C**

SKU NO: MS2009CCBGLO  
UPC CODE: 810053674130  
EAN CODE: 8435394779201

**FEATURE**

- Auto & Manual Ranging.
- Auto Power Off.
- Non-Contact Voltage Detector.
- Diode Open Volatge 3.2V.

**SPECIFICATIONS**

AC Voltage <b>600V</b>	DC Voltage <b>600V</b>	AC Current <b>600A</b>
Resistance <b>60MΩ</b>	Capacitance <b>60mF</b>	Frequency(A/V) <b>1kHz/10kHz</b>
Display Counts <b>6000</b>	Jaw Opening <b>26mm/1.0"</b>	Continuity <b>&lt;50Ω</b>

**CONTENTS**



218×78×35mm  
8.9"×3.1"×1.4"  
239g/0.53lb



3×1.5V AAA  
Batteries



**ACCESSORIES**

Test Leads/K type thermocouple/  
Carry bag/Battery



Calibration  
Certificate



Quick  
Start Guide

**PACKAGING INFORMATION**



**Color Box**  
L105×W55×H235mm



**Carton Box**  
50×30.5×23cm



**X 20PCS**





**MAIN APPLICATIONS**

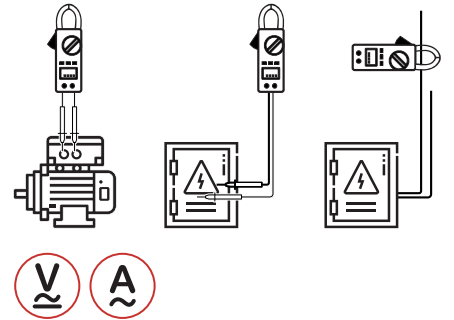
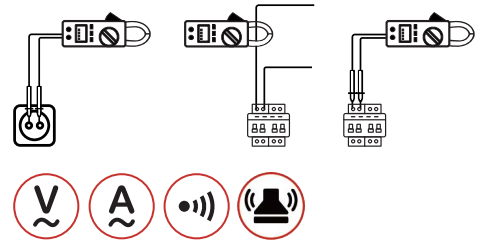

**DIGITAL AC CLAMP METER**  
**MS2025A**

SKU NO: MS2025ACBGLO  
UPC CODE: 810053674147  
EAN CODE: 8435394779218

**FEATURE**

- Auto & Manual Ranging.
- Auto Power Off.
- Non-Contact Voltage Detector
- Relative Measurement.

**SPECIFICATIONS**

AC Voltage <b>750V</b>	DC Voltage <b>1000V</b>	AC Current <b>1000A</b>
Resistance <b>60MΩ</b>	Capacitance <b>100mF</b>	Display Counts <b>6000</b>
Jaw Opening <b>40mm/1.6"</b>	Continuity <b>&lt;50Ω</b>	

**CONTENTS**



238×92×50mm  
9.37"×3.6"×1.9"  
390g/0.86lb



1×9V 6F22  
Battery



**ACCESSORIES**

Test Leads/Carry bag/  
Battery



Calibration  
Certificate



Quick  
Start Guide

**PACKAGING INFORMATION**



**Color Box**  
L130×W63×H255mm



**Carton Box**  
53×34×28.5cm



**X 20PCS**



**MAIN APPLICATIONS**

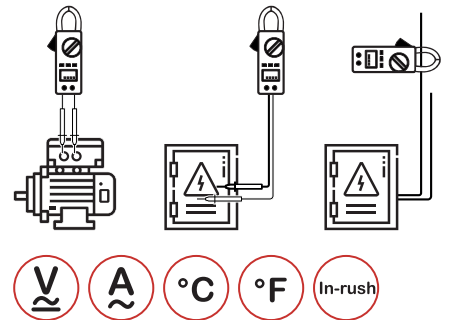
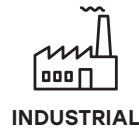
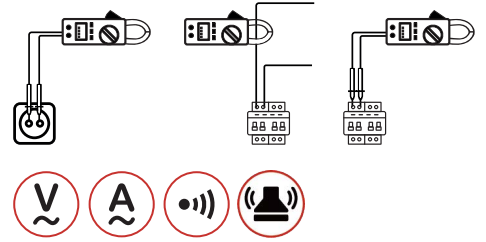

**DIGITAL AC CLAMP METER**  
**MS2025C**

SKU NO: MS2025CCBGLO  
UPC CODE: 810053674635  
EAN CODE: 8435394779690

**FEATURE**

- Auto & Manual Ranging.
- Auto Power Off.
- Non-Contact Voltage Detector
- Relative Measurement.

**SPECIFICATIONS**

AC Voltage <b>750V</b>	DC Voltage <b>1000V</b>	AC Current <b>1000A</b>
Resistance <b>66MΩ</b>	Capacitance <b>66mF</b>	Continuity <b>&lt;50Ω</b>
Frequency(A/V) <b>66Hz/6.6kHz</b>	Display Counts <b>6600</b>	Jaw Opening <b>40mm/1.6"</b>

**CONTENTS**



238×92×50mm  
9.37"×3.6"×1.9"  
390g/0.86lb



1×9V 6F22  
Battery



**ACCESSORIES**

Test Leads/Carry bag/ K type thermocouple  
Battery



Calibration  
Certificate



Quick  
Start Guide

**PACKAGING INFORMATION**



**Color Box**  
L130×W63×H255mm



**Carton Box**  
53×34×28.5cm



**X 20CS**



**MAIN APPLICATIONS**

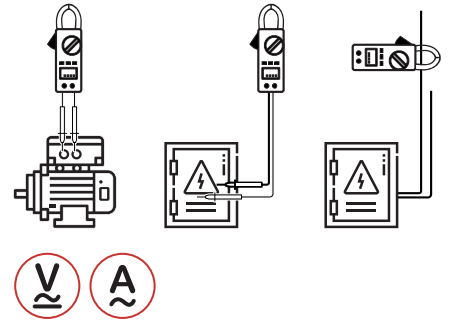
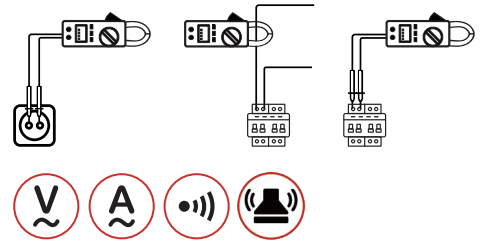

**DIGITAL AC CLAMP METER**  
**MS2028A**

SKU NO: MS2028ACBGLO  
UPC CODE: 810053674642  
EAN CODE: 8435394779706

**FEATURE**

- Auto & Manual Ranging.
- Auto Power Off.
- Diode Open Voltage 1.5V.
- True Root Mean Square.

**SPECIFICATIONS**

AC Voltage <b>600V</b>	DC Voltage <b>600V</b>	DC Current <b>600A</b>
Resistance <b>20MΩ</b>	Display Counts <b>2000</b>	Jaw Opening <b>26mm/1.0"</b>
Continuity <b>&lt;50Ω</b>		

**CONTENTS**



208x78x35mm  
8.2"x3.1"x1.4"  
245g/0.54lb



3x1.5V AAA  
Batteries



**ACCESSORIES**

Test Leads/Carry Bag/  
Battery



Calibration  
Certificate



Quick  
Start Guide

**PACKAGING INFORMATION**



**Color Box**  
L105xW55xH235mm



**Carton Box**  
50x30.5x23cm



**X 20PCS**



**MAIN APPLICATIONS**

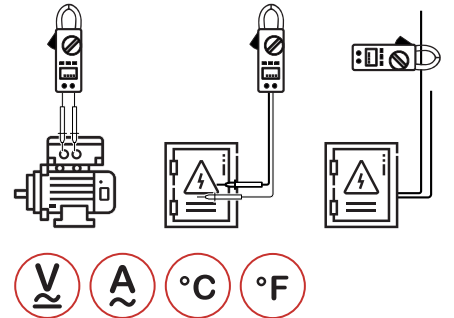
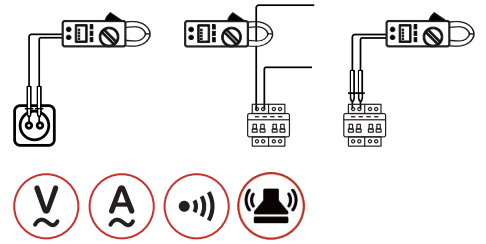

**DIGITAL AC CLAMP METER**  
**MS2030B**

SKU NO: MS2030BCBGLO  
UPC CODE: 810053674666  
EAN CODE: 8435394779720

**FEATURE**

- Auto & Manual Ranging.
- Auto Power Off.
- Data Hold.
- Non-Contact Voltage Detector.

**SPECIFICATIONS**

AC Voltage <b>600V</b>	DC Voltage <b>600V</b>	AC Current <b>600A</b>
Resistance <b>40MΩ</b>	Capacitance <b>100μF</b>	Frequency <b>10kHz</b>
Display Counts <b>4000</b>	Jaw Opening <b>28mm/1.1"</b>	Continuity <b>&lt;50±20Ω</b>
Temperature <b>-20~1000°C / -4~1832°F</b>		

**CONTENTS**



198×79×38mm  
7.8"×3.1"×1.5"  
195g/0.43lb



3×1.5V AAA  
Batteries



**ACCESSORIES**

Test Leads/Carry Bag/K type thermocouple/  
Battery



Calibration  
Certificate



Quick  
Start Guide

**PACKAGING INFORMATION**



**Color Box**  
L105×W55×H235mm



**Carton Box**  
50×30.5×23cm



**X 20PCS**



### MAIN APPLICATIONS

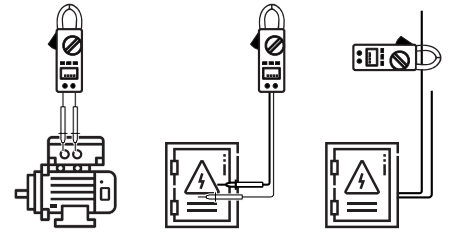
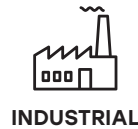
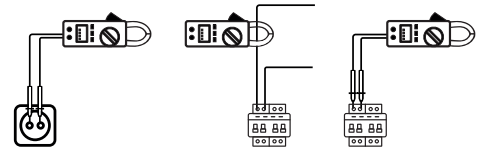

## SMART DIGITAL CLAMP METER MS2033A

SKU NO: MS2033ACBGLO  
UPC CODE: 810053674932  
EAN CODE: 8435394782676

### FEATURE

- Auto Ranging.
- Auto Power Off.
- Dual Display.
- MAX/MIN.

### SPECIFICATIONS

AC Voltage <b>600V</b>	DC Voltage <b>600V</b>	AC Current <b>600A</b>
Resistance <b>10MΩ</b>	Frequency <b>3kHz</b>	Display Counts <b>6000</b>
Jaw Opening <b>26mm/1.0"</b>	Continuity <b>&lt;40Ω</b>	

### CONTENTS



204×78×43mm  
8"×3.07"×1.77"  
195g/0.43lb



3×1.5V AAA  
Batteries



ACCESSORIES

Test Leads/  
Battery



Calibration  
Certificate



Quick  
Start Guide

### PACKAGING INFORMATION



Color Box  
L105×W55×H235mm



Carton Box  
50×30.5×23cm



X 20PCS



**MAIN APPLICATIONS**

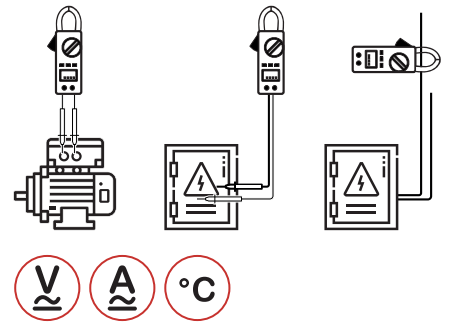
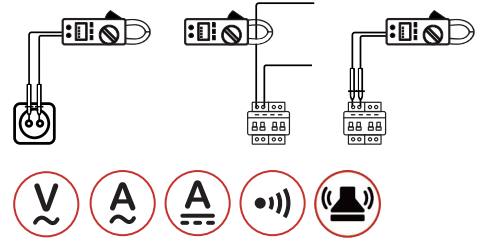

**DIGITAL AC/DC CLAMP METER**  
**MS2109A**

SKU NO: MS2109ACBGLO  
UPC CODE: 810053672112  
EAN CODE: 8435394777849

**FEATURE**

- Auto Ranging.
- Auto Power Off.
- Non-Contact Voltage Detector.
- Relative Measurement.

**SPECIFICATIONS**

AC Voltage <b>600V</b>	DC Voltage <b>600V</b>	AC Current <b>600A</b>
DC Current <b>600A</b>	Resistance <b>60MΩ</b>	Capacitance <b>4000μF</b>
Frequency(A/V) <b>1kHz/10kHz</b>	Display Counts <b>6000</b>	Jaw Opening <b>26mm/1.0"</b>
Temperature <b>-20~1000°C/-4~1832°F</b>	Continuity <b>&lt;50±20Ω</b>	

**CONTENTS**



218×78×35mm  
8.9"×3.1"×1.4"  
239g/0.53lb



3×1.5V AAA  
Batteries



**ACCESSORIES**

Test Leads/Carry Bag/K type thermocouple/  
Battery



Calibration  
Certificate



Quick  
Start Guide

**PACKAGING INFORMATION**



**Color Box**  
L105xW55xH235mm



**Carton Box**  
50×30.5×23cm



**X 20PCS**



**MAIN APPLICATIONS**

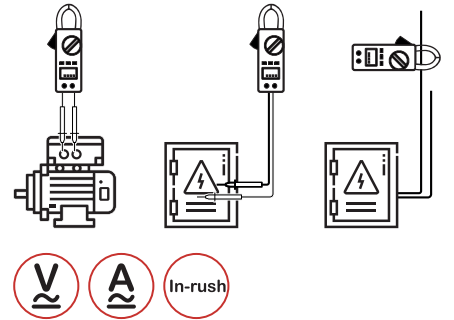
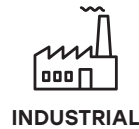
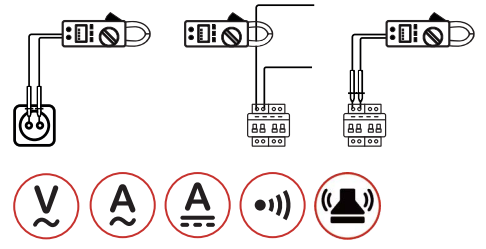

**DIGITAL AC/DC CLAMP METER**  
**MS2125A**

SKU NO: MS2125ACBGLO  
UPC CODE: 810053672129  
EAN CODE: 8435394777856

**FEATURE**

- Auto & Manual Ranging.
- Auto Power Off.
- Non-Contact Voltage Detector.
- Relative Measurement.

**SPECIFICATIONS**

AC Voltage <b>750V</b>	DC Voltage <b>1000V</b>	AC Current <b>1000A</b>
DC Current <b>1000A</b>	Resistance <b>60MΩ</b>	Capacitance <b>100mF</b>
Frequency(A/V) <b>1kHz/10kHz</b>	Display Counts <b>6000</b>	Jaw Opening <b>40mm/1.6"</b>
Continuity <b>&lt;50Ω</b>		

**CONTENTS**



238×92×50mm  
9.37"×3.6"×1.9"  
386g/0.85lb



1×9V 6F22  
Battery



**ACCESSORIES**

Test Leads/Carry Bag/  
Battery



Calibration  
Certificate



Quick  
Start Guide

**PACKAGING INFORMATION**



**Color Box**  
L130×W63×H255mm



**Carton Box**  
53×34×28.5mm



**X 20PCS**



**MAIN APPLICATIONS**

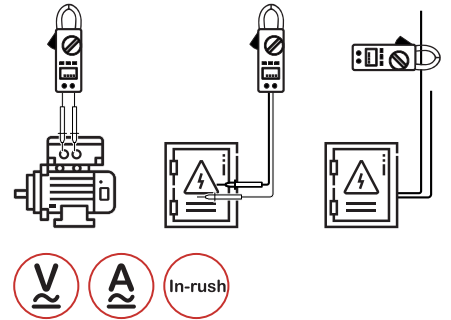
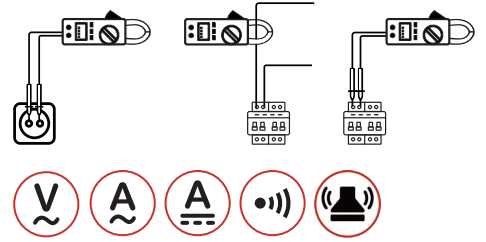

**DIGITAL AC/DC CLAMP METER**  
**MS2128**

SKU NO: MS2128CBGLO  
UPC CODE: 810053674178  
EAN CODE: 8435394779249

**FEATURE**

- Auto & Manual Ranging.
- Auto Power Off.
- Inrush 100ms Current Integral.
- True Root Mean Square.

**SPECIFICATIONS**

AC Voltage <b>600V</b>	DC Voltage <b>600V</b>	AC Current <b>400A</b>
DC Current <b>400A</b>	Resistance <b>40MΩ</b>	Capacitance <b>4000uF</b>
Frequency(A/V) <b>1kHz/10kHz</b>	Display Counts <b>6600</b>	Jaw Opening <b>26mm/1.0"</b>
Continuity <b>&lt;50±20Ω</b>		

**CONTENTS**



208×78×53mm  
8.2"×3.1"×1.4"  
245g/0.54lb



3×15V AAA  
Batteries



**ACCESSORIES**

Test Leads/Carry Bag/  
Battery



Calibration  
Certificate



Quick  
Start Guide

**PACKAGING INFORMATION**



**Color Box**  
L105×W55×H235mm



**Carton Box**  
50×30.5×23cm



**X 20PCS**





**MAIN APPLICATIONS**

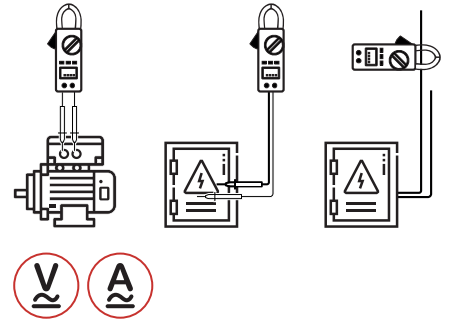
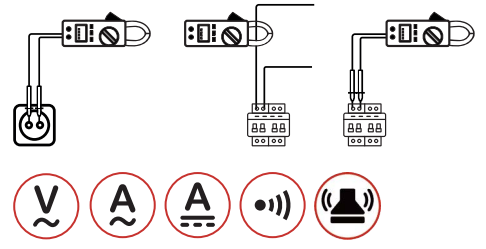

**DIGITAL AC/DC CLAMP METER**  
**MS2128A**

SKU NO: MS2128ACBGLO  
UPC CODE: 810053674673  
EAN CODE: 8435394779737

**FEATURE**

- Auto & Manual Ranging.
- Auto Power Off.
- Relative measurement.
- Diode Open Voltage 3.0V.

**SPECIFICATIONS**

AC Voltage <b>600V</b>	DC Voltage <b>600V</b>	AC Current <b>400A</b>
DC Current <b>400A</b>	Resistance <b>40MΩ</b>	Capacitance <b>4000μF</b>
Frequency(A/V) <b>1kHz/10kHz</b>	Frequency(Hz/Duty) <b>10kHz/10MHz</b>	Display Counts <b>4000</b>
Jaw Opening <b>26mm/1.0"</b>	Continuity <b>&lt;50±20Ω</b>	

**CONTENTS**



208×78×53mm  
8.2"×3.1"×1.4"  
245g/0.54lb



3×1.5V AAA  
Batteries



**ACCESSORIES**

Test Leads/Carry Bag/  
Battery



Calibration  
Certificate



Quick  
Start Guide

**PACKAGING INFORMATION**



**Color Box**  
L105×W55×H235mm



**Carton Box**  
50×30.5×23cm



**X 20PCS**



**MAIN APPLICATIONS**

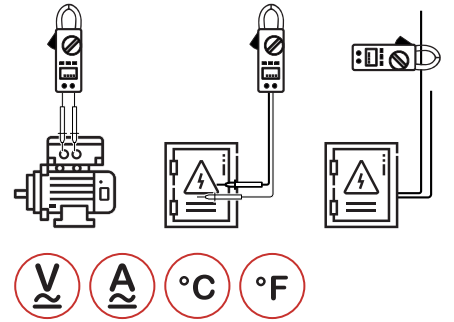
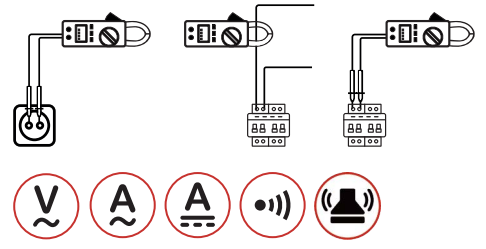

**DIGITAL AC/DC CLAMP METER**  
**MS2160**

SKU NO: MS2160CBGLO  
UPC CODE: 810053674185  
EAN CODE: 8435394779256

**FEATURE**

- Auto & Manual Ranging.
- Auto Power Off.
- Non-Contact Voltage Detector.
- Diode Open Voltage 3.2V.

**SPECIFICATIONS**

AC Voltage <b>600V</b>	DC Voltage <b>600V</b>	AC Current <b>80A</b>
DC Current <b>80A</b>	Resistance <b>40MΩ</b>	Capacitance <b>40mF</b>
Frequency <b>1kHz/10kHz</b>	Display Counts <b>4000</b>	Continuity <b>&lt;50Ω</b>
Jaw Opening <b>24mm/0.9"</b>	Temperature <b>-20~1000°C/-4~1832°F</b>	

**CONTENTS**



195×80×45mm  
7.8"×3.1"×1.8"  
195g/0.43lb



3×1.5V AAA  
Battery



**ACCESSORIES**

Test Leads/Carry bag/K type thermocouple/  
Battery



Calibration  
Certificate



Quick  
Start Guide

**PACKAGING INFORMATION**



**Color Box**  
L105×W55×H235mm



**Carton Box**  
50×30.5×23cm



**X 20PCS**



**MAIN APPLICATIONS**

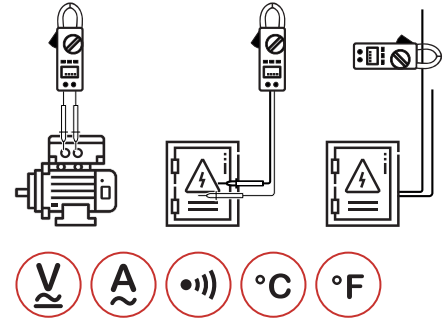

**DIGITAL AC CLAMP METER**  
**MS2601**

SKU NO: MS2601CBGLO  
UPC CODE: 810053674215  
EAN CODE: 8435394779287

**FEATURE**

- Auto & Manual Ranging.
- Auto Power Off..
- Non-Contact Voltage Detector.
- Diode Open Voltage 3.2V.

**SPECIFICATIONS**

AC Voltage <b>600V</b>	DC Voltage <b>600V</b>	AC Current <b>200A</b>
Resistance <b>60MΩ</b>	Capacitance <b>60mF</b>	Frequency(A/V) <b>60Hz/60MHz</b>
Display counts <b>6000</b>	Jaw opening <b>12mm/0.5"</b>	Continuity <b>&lt;50Ω</b>
Temperature <b>-20~400°C / -4~752°F</b>		

**CONTENTS**



201×65×43mm  
7.7"×2.6"×1.7"  
265g/0.58lb



1×9V 6F22  
Battery



ACCESSORIES

Test Leads/Carry bag/K type thermocouple/  
Battery



Calibration  
Certificate



Quick  
Start Guide

**PACKAGING INFORMATION**



**Color Box**  
L172×W80×H255mm



**Carton Box**  
53×44.5×37cm



**X 20PCS**



**MAIN APPLICATIONS**

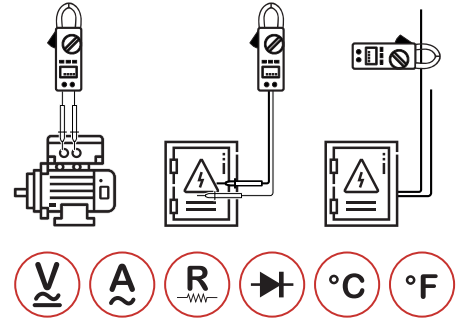

**AC LEAKAGE CLAMP METER**  
**MS2016A**

SKU NO: MS2016ACBGLO  
UPC CODE: 810053675052  
EAN CODE: 8435394783062

**FEATURE**

- Auto Ranging.
- Auto Power Off.
- True RMS For AC Voltage.
- Low Pass Filter Function (50/60Hz).

**SPECIFICATIONS**

AC Voltage <b>600V</b>	DC Voltage <b>600V</b>	AC Current <b>150A</b>
Resistance <b>40MΩ</b>	Capacitance <b>40mF</b>	Jaw Opening <b>30mm/1.2"</b>
Display Counts <b>4000</b>	Temperature <b>-20~1000°C/-4~1832°F</b>	

**CONTENTS**



213×62×38mm  
8.39"×2.44"×1.5"  
238g/0.52lb



2×1.5V AAA  
Batteries



ACCESSORIES

Test Leads/K type thermocouple/  
Battery



Calibration  
Certificate



Quick  
Start Guide

**PACKAGING INFORMATION**



**Color Box**  
L105×W55×H235mm



**Carton Box**  
50×30.5×23cm



**X 20PCS**



**MAIN APPLICATIONS**

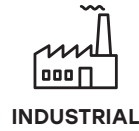

INDUSTRIAL

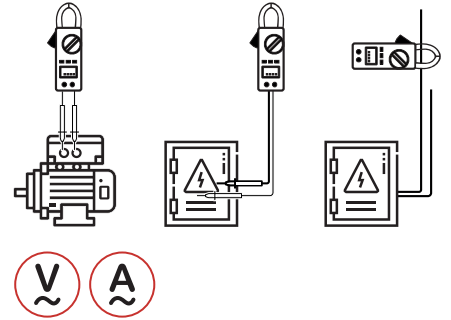

**CONTENTS**



300×103×51mm  
11.8"×4.1"×2.0"  
640g/1.4lb



4×1.5V AA  
Batteries



ACCESSORIES

Test Leads/Alligator clip/ RS232C interface cable/  
PC Data Record graph software/Carry Case/  
Battery



Calibration  
Certificate



Quick  
Start Guide

**THREE PHASE DIGITAL POWER CLAMP METER**  
**MS2203**

SKU NO: MS2203CBGLO  
UPC CODE: 810053672570  
EAN CODE: 8435394778211

**FEATURE**

- Auto & Manual Ranging.
- Data Logging 28 groups.
- True Root Mean Square.
- Bar Graph.

**SPECIFICATIONS**

AC Voltage <b>600V</b>	AC Current <b>1000A</b>	Frequency <b>1000Hz</b>
Active Power <b>600kW</b>	Apparent Power <b>600kVA</b>	Reactive Power <b>600kVAr</b>
Jaw Opening <b>50mm/2.0"</b>	Display Counts <b>9999</b>	

**PACKAGING INFORMATION**



**Color Box**  
L370×W140×H324mm



**Carton Box**  
58×39×35cm



**X 4PCS**



**MAIN APPLICATIONS**



DOMESTIC

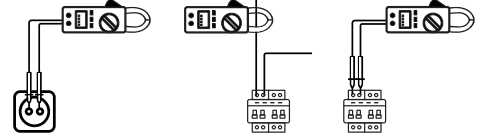

INDUSTRIAL

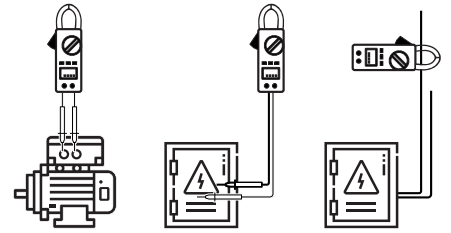

**THREE PHASE DIGITAL POWER CLAMP METER**  
**MS2205**

SKU NO: MS2205CBAGLO  
UPC CODE: 810053674192  
EAN CODE: 8435394779263

**FEATURE**

- Auto & Manual Ranging.
- Auto Power Off.
- Data Hold.
- True Root Mean Square.

**SPECIFICATIONS**

AC Voltage <b>600V</b>	AC Current <b>1000A</b>	Frequency <b>1000Hz</b>
Display Counts <b>6000</b>	Data logging <b>100 groups</b>	Jaw Opening <b>50mm/2.0"</b>

**CONTENTS**



300x103x51mm  
11.8"x4.1"x2.0"  
640g/1.4lb



4x1.5V AA Batteries



ACCESSORIES

Test Leads/Alligator clip/ RS232C interface cable/  
PC Data Record graph software/Carry Case/  
Battery



Calibration Certificate



Quick Start Guide

**PACKAGING INFORMATION**



**Color Box**  
L370xW140xH324mm



**Carton Box**  
58x39x35cm



X 4PCS



**MAIN APPLICATIONS**

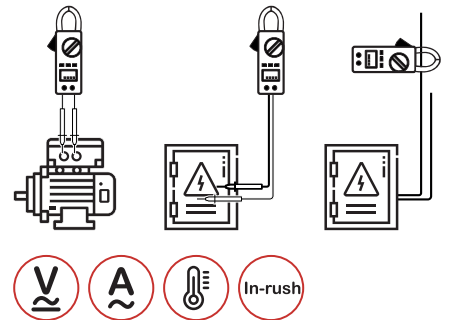
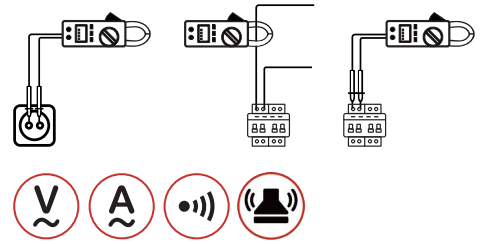

**SINGLE PHASE POWER CLAMP METER**  
**MS2225A**

SKU NO: MS2225ACBGLO  
UPC CODE: 810053674680  
EAN CODE: 8435394779744

**FEATURE**

- Auto & Manual Ranging.
- Auto Power Off.
- True Root Mean Square.
- Diode Open voltage 3.2V.

**SPECIFICATIONS**

AC Voltage <b>750V</b>	DC Voltage <b>1000V</b>	AC Current <b>1000A</b>
Resistance <b>60MΩ</b>	Capacitance <b>1000mF</b>	Continuity <b>&lt;50Ω</b>
Frequency(A/V) <b>1kHz/10kHz</b>	Display Counts <b>6000</b>	Jaw Opening <b>40mm/1.6"</b>

**CONTENTS**



250×98×53mm  
9.84"×3.78"×2.09"  
450g/0.99lb



1×9V 6F22  
Battery



**ACCESSORIES**

Test Leads/Alligator clip(option)/Carry bag/  
Battery



Calibration  
Certificate



Quick  
Start Guide

**PACKAGING INFORMATION**



**Color Box**  
L130×W63×H255mm



**Carton Box**  
53×34×28.5cm



**X 20PCS**

# ELECTRICAL TESTERS

NON CONTACT VOLTAGE TESTERS  
TWO POLE VOLTAGE TESTERS







**MAIN APPLICATIONS**

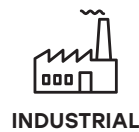
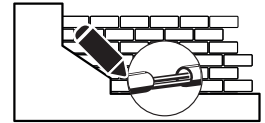

**NCV WITH INFRARED THERMOMETER**  
**MS6580B**

SKU NO: MS6580BCBGLO  
UPC CODE: 810053675250  
EAN CODE: 8435394783260

**FEATURE**

- Non-Contact Voltage Detector.
- NCV Sensitivity 4Levels.
- Infrared Temperature.
- Spectral Response 8-14 μm.

**SPECIFICATIONS**

AC Voltage <b>1000V</b>	Temperature <b>-20~330°C/-4~626°F</b>
Repeatability <b>±0.1°C</b>	Emissivity <b>0.95</b>

**CONTENTS**

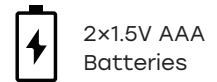
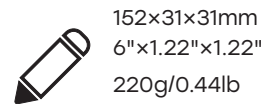

**PACKAGING INFORMATION**

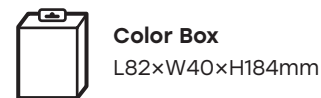



**MAIN APPLICATIONS**

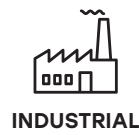
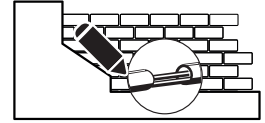

**NON CONTACT AC VOLTAGE DETECTOR**  
**MS8900**

SKU NO: MS8900CBGLO  
UPC CODE: 810053672723  
EAN CODE: 8435394778365

**FEATURE**

- Sound and Light Instruction.
- Double Molded Case.
- Operating Temperature 0°C~50°C.

**SPECIFICATIONS**

AC Voltage <b>100~240V</b>	Frequency <b>50Hz~60Hz</b>	Humidity <b>85%RH</b>
-------------------------------	-------------------------------	--------------------------

**CONTENTS**

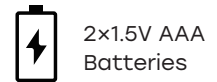
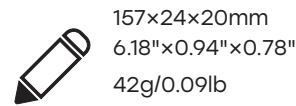

**PACKAGING INFORMATION**

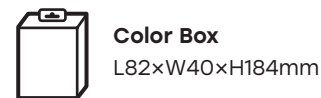



**MAIN APPLICATIONS**

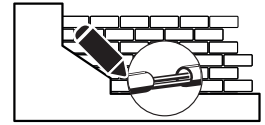

**NON CONTACT AC VOLTAGE DETECTOR**  
**MS8900A**

SKU NO: MS8900ACBGLO  
UPC CODE: 810053673041  
EAN CODE: 8435394778778

**FEATURE**

- Sound and Light Instruction.
- Double Molded Case.
- Operating Temperature 0°C~50°C.

**SPECIFICATIONS**

AC Voltage  
**90~1000V**

Frequency  
**50Hz~60Hz**

Humidity  
**85%RH**

Altitude  
**<2000m**

**CONTENTS**

 157×24×20mm  
6.18"×0.94"×0.78"  
42g/0.09lb

 2×1.5V AAA  
Batteries

 Battery  
**ACCESSORIES**

 Calibration  
Certificate

 Quick  
Start Guide

**PACKAGING INFORMATION**

 **Color Box**  
L82×W40×H184mm

 **Carton Box**  
39×22×35.5cm

 **X 40PCS**



**MAIN APPLICATIONS**



DOMESTIC

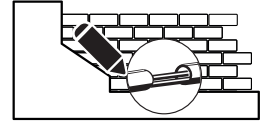

INDUSTRIAL



**NON CONTACT AC VOLTAGE DETECTOR**  
**MS8900C**

SKU NO: MS8900CCBGLO  
UPC CODE: 810053675373  
EAN CODE: 8435394783413

**FEATURE**

- Sound and Light Instruction.
- Double Molded Case.
- Operating Temperature 0°C~50°C.

**SPECIFICATIONS**

AC Voltage <b>100~240V</b>	Frequency <b>50Hz~60Hz</b>	Humidity <b>85%RH</b>
Altitude <b>&lt;2000m</b>		

**CONTENTS**

 157×24×20mm  
6.18"×0.94"×0.78"  
42g/0.09lb

 2×1.5V AAA  
Batteries

 Battery  
**ACCESSORIES**

 Calibration  
Certificate

 **QSG**  
Quick  
Start Guide

**PACKAGING INFORMATION**

 **Color Box**  
L82×W40×H184mm

 **Carton Box**  
39×22×35.5cm

 **X 40PCS**



**MAIN APPLICATIONS**

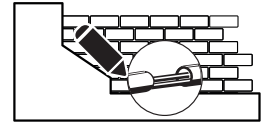

**NON CONTACT AC VOLTAGE DETECTOR**  
**MS8902A**

SKU NO: MS8902ACBGLO  
UPC CODE: 810053672730  
EAN CODE: 8435394778372

**FEATURE**

- Sound and Light Instruction.
- Double Molded Case.
- Operating Temperature -10°C~50°C.

**SPECIFICATIONS**

AC Voltage <b>12~1000V</b>	Frequency <b>50Hz~500Hz</b>	Humidity <b>85%RH</b>
Altitude <b>&lt;2000m</b>		

**CONTENTS**

157×24×20mm 6.18"×0.94"×0.78" 42g/0.09lb	2×1.5V AAA Batteries
Battery	
Calibration Certificate	Quick Start Guide

**PACKAGING INFORMATION**

<b>Color Box</b> L82×W40×H184mm	
<b>Carton Box</b> 39×22×35.5cm	<b>X 40PCS</b>



**MAIN APPLICATIONS**

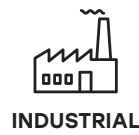
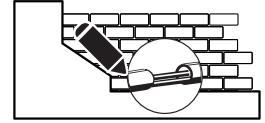

**NON CONTACT AC VOLTAGE DETECTOR**  
**MS8902B**

SKU NO: MS8902BCBGLO  
UPC CODE: 810053674505  
EAN CODE: 8435394779577

**FEATURE**

- Sound and Light Instruction.
- Double Molded Case.
- Operating Temperature -10°C~50°C.

**SPECIFICATIONS**

AC Voltage  
**20~1000V**

Frequency  
**50Hz~500Hz**

Humidity  
**85%RH**

Altitude  
**<2000m**

**CONTENTS**



157×24×20mm  
6.18"×0.94"×0.78"  
42g/0.09lb



2×1.5V AAA  
Batteries



ACCESSORIES

Battery



Calibration  
Certificate



Quick  
Start Guide

**PACKAGING INFORMATION**



**Color Box**  
L82×W40×H184mm



**Carton Box**  
39×22×35.5cm



**X 40PCS**



**MAIN APPLICATIONS**

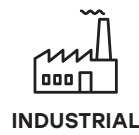
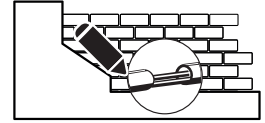

**NON CONTACT AC VOLTAGE DETECTOR**  
**MS8907**

SKU NO: MS8907CBGLO  
UPC CODE: 810053674789  
EAN CODE: 8435394779843

**FEATURE**

- Sound and Light Instruction.
- Work Light.
- Operating Temperature -10°C~50°C.

**SPECIFICATIONS**

AC Voltage <b>50~1000V</b>	Frequency <b>50Hz/60Hz</b>	Humidity <b>85%RH</b>
Altitude <b>&lt;2000m</b>		

**CONTENTS**

157×24×20mm  
6.2"×0.95"×0.79"  
42g/0.09lb

2×1.5V AAA Batteries

Battery  
**ACCESSORIES**

Calibration Certificate

Quick Start Guide

**PACKAGING INFORMATION**

**Color Box**  
L82×W40×H184mm

**Carton Box**  
39×22×35.5cm

**X 40PCS**



**MAIN APPLICATIONS**



DOMESTIC

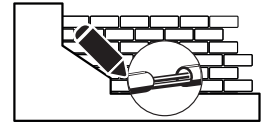

INDUSTRIAL



**VOLTAGE TESTER**

**MS8922A**

SKU NO: MS8922ACBGLO  
 UPC CODE: 810053674529  
 EAN CODE: 8435394779591

**FEATURE**

- Ergonomic design that facilitates its use.
- Operation Time Maximum 30s.
- Recovery Time 10 minutes.

**SPECIFICATIONS**

AC Voltage  
**400V**

DC Voltage  
**400V**

Frequency  
**50Hz/60Hz**

Altitude  
**<2000m**

**CONTENTS**



223x40x32mm  
 8.78"x1.57"x1.26"  
 98.5g/0.26lb



Calibration Certificate



Quick Start Guide

**PACKAGING INFORMATION**



**Color Box**  
 L125xW40xH255mm



**Carton Box**  
 53x22x27cm



**X 20PCS**





**MAIN APPLICATIONS**

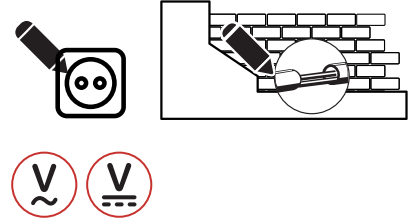

**VOLTAGE TESTER WITH RCD**  
**MS8922B**

SKU NO: MS8922BCBGLO  
UPC CODE: 810053674536  
EAN CODE: 8435394779607

**FEATURE**

- RCD Test function.
- Operation Time Maximum 30s.
- Recovery Time 10 minutes.
- Operation Temperature -10~55°C/14~131°F.

**SPECIFICATIONS**

AC Voltage <b>400V</b>	DC Voltage <b>400V</b>	Frequency <b>50Hz/60Hz</b>
Altitude <b>&lt;2000m</b>		

**CONTENTS**

223x40x32mm  
8.78"x1.57"x1.26"  
98.5g/0.26lb

Calibration Certificate

Quick Start Guide

**PACKAGING INFORMATION**

**Color Box**  
L125xW40xH255mm

**Carton Box**  
53x22x27cm **X 20PCS**

# CIRCUIT TESTERS

CIRCUIT BREAKER FINDERS | SOCKET TESTERS

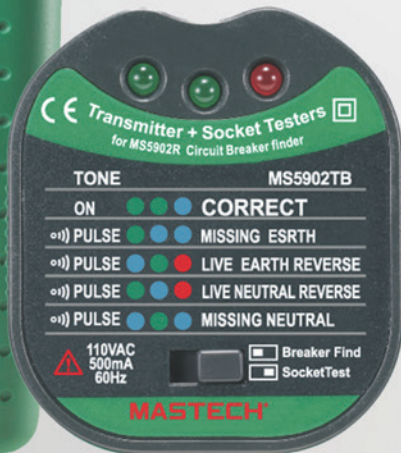



MS5902TD



MS5902TE



**MAIN APPLICATIONS**

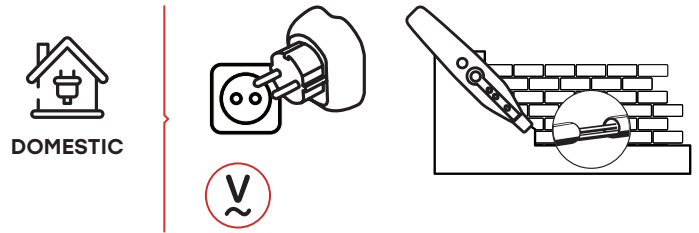

**CONTENTS**

	MS5902R: 198×40×50mm 7.8"×1.57"×1.97" 126g/0.28lb	MS5902TD/TE: 71×64×55mm 2.8"×2.5"×2.16" 60g/0.13lb	MS5902TF: 82×42×32mm 3.2"×1.65"×1.26" 35g/0.1lb
--	--	---	--

- Battery: 1x9V 6F22 Battery
- ACCESSORIES
- Calibration Certificate
- QSG Quick Start Guide

**CIRCUIT BREAKER FINDER**

**MS5902RT**

SKU NO	MS5902RTDCBGLO	MS5902RTECBGLO
UPC CODE	810053672877	810053675106
EAN CODE	8435394778556	8435394783093

**FEATURE**

- Socket Tester and Circuit Breaker Finder.
- Sound and Light Signals.
- Professional Reference.

**SPECIFICATIONS**

AC Voltage(TD) <b>230V</b>	AC Voltage(TE) <b>230V</b>	AC Voltage(TF) <b>120V</b>
-------------------------------	-------------------------------	-------------------------------

**PACKAGING INFORMATION**

- Color Box**  
L130×W63×H255mm
- Carton Box**  
53×34×28.5cm
- X 20PCS**



MS5905TD



MS5905RTE

**MAIN APPLICATIONS**

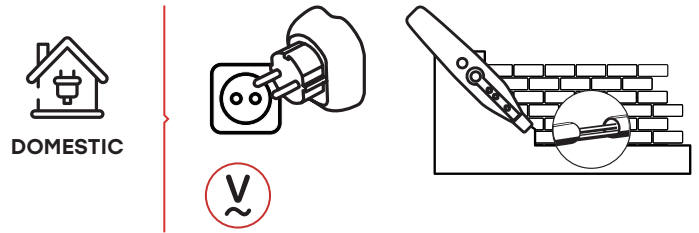

**CONTENTS**



MS5905R:  
177x46x31mm  
6.97"x1.81"x1.22"  
130g/0.29lb

MS5905TD/TE:  
71x64x55mm  
2.8"x2.5"x2.16"  
63g/0.14lb



Battery

ACCESSORIES



1x9V 6F22 Battery



Calibration Certificate



Quick Start Guide

**CIRCUIT BREAKER FINDER with NCV**  
**MS5905RT**

SKU NO	MS5905RTDCBGLO	MS5905RTECBGLO
UPC CODE	810053675120	810053673126
EAN CODE	8435394783116	8435394778853

**FEATURE**

- Socket Tester and Circuit Breaker Finder.
- Sound and Light Signals.
- Professional Reference.

**SPECIFICATIONS**

AC Voltage(TD)	AC Voltage(TE)
<b>230V</b>	<b>230V</b>

**PACKAGING INFORMATION**



**Color Box**  
L130xW63xH255mm



**Carton Box**  
53x34x28.5cm



**X 40PCS**



MS6860D



MS6860E

**SOCKET TESTER**

# MS6860

SKU NO	MS6860DCBGLO	MS6860ECBGLO
UPC CODE	810053674369	810053675281
EAN CODE	8435394779430	8435394783307

**FEATURE**

- Reliable and Easy to Use Modern, Ergonomic Design with Unique Soft Finger Grip Compact, Durable-Designed to Safety Standard EN61010.

**SPECIFICATIONS**

AC Voltage(MS6860D)  
**230V**

AC Voltage(MS6860E)  
**230V**

**MAIN APPLICATIONS**



**CONTENTS**

68x60x56mm  
2.67"x2.36"x2.2"  
60g/0.13lb

Calibration Certificate

Quick Start Guide

**PACKAGING INFORMATION**

**Color Box**  
L88xW65xH100mm

**Carton Box**  
34.5x22x38cm

**X 40PCS**

# CIRCUIT ANALYZERS

MOTOR & PHASE ROTATION INDICATOR  
CIRCUIT ANALYZER

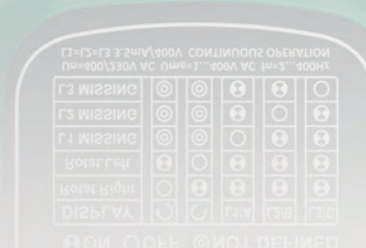

MOTOR & PHASE ROTATION INDICATOR  
MS5901



**MAIN APPLICATIONS**

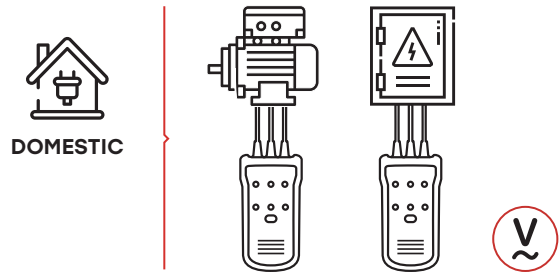

**CONTENTS**

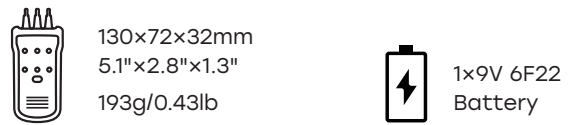

**MOTOR & PHASE ROTATION INDICATOR**  
**MS5901**

SKU NO: MS5901CBGLO  
UPC CODE: 810053672921  
EAN CODE: 8435394778655

**FEATURE**

- Motor & phase rotation tester.
- Led light signals.
- Operating Altitude 2000m.
- Pollution Degree 2.

**SPECIFICATIONS**

AC Voltage <b>120~400V</b>	Frequency <b>2~400Hz</b>	Humidity <b>15~80%RH</b>
Temperature <b>0~40°C/3~104°F</b>		

**PACKAGING INFORMATION**

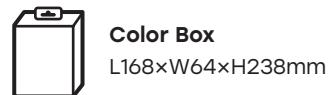



**MAIN APPLICATIONS**

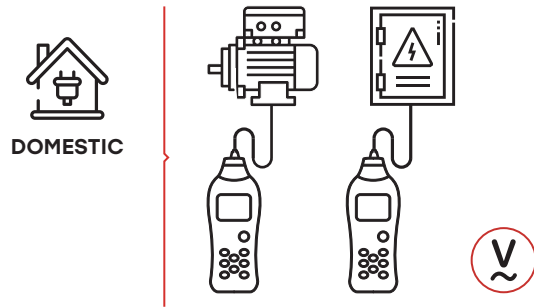

**CONTENTS**



194x78x37mm  
7.64"x3.07"x1.46"  
254g/0.56lb



6x1.5V AAA Batteries



ACCESSORIES

Power Cord/Carry bag/  
Battery



Calibration  
Certificate



Quick  
Start Guide

**CIRCUIT ANALYZER**

**MS5908A**

SKU NO: MS5908ACBGLO  
UPC CODE: 810053673119  
EAN CODE: 8435394778846

**FEATURE**

- Auto Power Off.
- Data Hold.
- Low Battery Display.

**SPECIFICATIONS**

Line Voltage  
**85~135V**

Peak Line Voltage  
**120~190V**

Frequency  
**45~65Hz**

Voltage Drop Load Current  
**12/15/20A**

**PACKAGING INFORMATION**



**Color Box**  
L130xW63xH255mm



**Carton Box**  
53x34x28.5cm



**X 20PCS**





**MAIN APPLICATIONS**

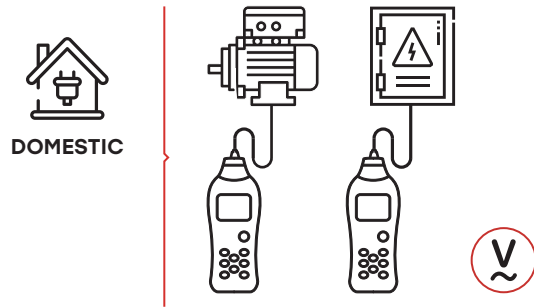

**CONTENTS**



194×78×37mm  
7.64"×3.07"×1.46"  
254g/0.56lb



6×1.5V AAA Batteries



ACCESSORIES

Power Cord/Carry bag/  
Battery



Calibration  
Certificate



Quick  
Start Guide

**CIRCUIT ANALYZER**

**MS5908C**

SKU NO: MS5908CCBGLO  
UPC CODE: 810053672808  
EAN CODE: 8435394778440

**FEATURE**

- Auto Power Off.
- Data Hold.
- Low Battery Display.

**SPECIFICATIONS**

Line Voltage  
**85~265V**

Peak Line Voltage  
**120~375V**

Frequency  
**45~65Hz**

Voltage Drop Load Current  
**5/8/10A**

**PACKAGING INFORMATION**



**Color Box**  
L130×W63×H255mm



**Carton Box**  
53×34×28.5cm



**X 20PCS**

# WIRE & CABLE TESTERS

NETWORK CABLE TESTER | CABLE TRACKER

MULTI-FUNCTIONS CABLE TRACKER | ADVANCED CABLE LOCATOR





**MAIN APPLICATIONS**

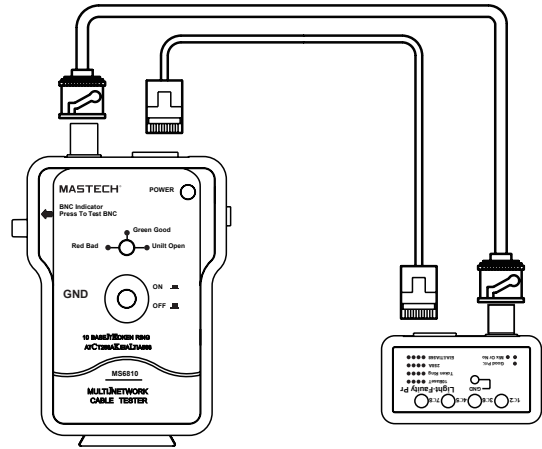

**NETWORK CABLE TESTER**  
**MS6810**

SKU NO: MS6810CBGLO  
UPC CODE: 810053674345  
EAN CODE: 8435394779416

**FEATURE**

- Widely Used For Coaxial Cable (BNC), UTP And STP Cable. It Can Automatically Check For Open Circuits, Shorts, Miswired, And Reversals.

**SPECIFICATIONS**

Distance  
**200m(max)**

**CONTENTS**



153×74×31mm  
6.0"×2.9"×1.2"  
120g/0.26lb



1×9V 6F22  
Battery



Battery

**ACCESSORIES**



Calibration  
Certificate



Quick  
Start Guide

**PACKAGING INFORMATION**



**Color Box**  
L90×W40×H165mm



**Carton Box**  
42.5×35×29cm



**X 60PCS**



**NETWORK CABLE TESTER**  
**MS6811**

SKU NO: MS6811CBGLO  
UPC CODE: 810053672624  
EAN CODE: 8435394778266

**FEATURE**

- Tests for Open Circuits, Shorts, Miswires, Reversals, and Split Pairs.
- DEBUG Quickly Identifies Which Cable Pairs Have A Specific Wiring Fault.

**SPECIFICATIONS**

Distance  
**200m(max)**

**MAIN APPLICATIONS**

**Fault details**

**Fig.1** SPLIT PAIRS

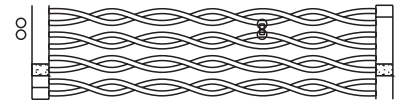

**Fig.2** SHORT

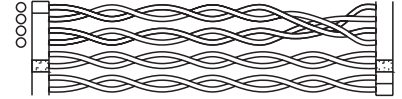

**Fig.3** MISWIRE

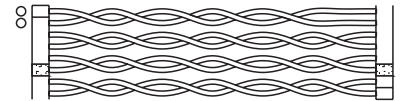

**Fig.4** REVERSED

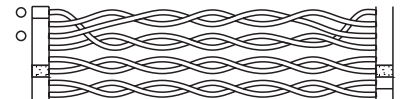

**CONTENTS**



125x55x30mm  
4.9"x2.2"x1.2"  
106g/0.23lb



1x6V 4LR44/  
4AG13 Battery



Battery

**ACCESSORIES**



Calibration  
Certificate



Quick  
Start Guide

**PACKAGING INFORMATION**



**Color Box**  
L90xW40xH165mm



**Carton Box**  
42.5x35x29cm



**X 60PCS**



**CABLE TRACKER**  
**MS6812A**

SKU NO: MS6812ACBGLO  
UPC CODE: 810053675274  
EAN CODE: 8435394783291

**FEATURE**

- Sound and Light Instruction.
- Cont and Tone LED Light.

**SPECIFICATIONS**

Send Tone Frequency  
**1.5kHz**

Receive Frequency  
**100Hz~300kHz**

**MAIN APPLICATIONS**

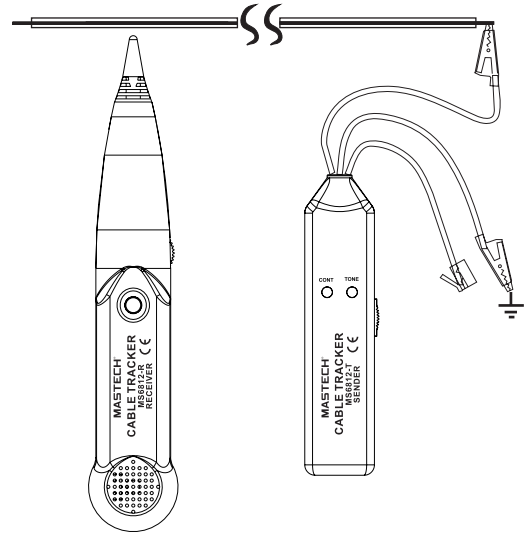

**CONTENTS**



Receiver:  
238×43×26mm  
9.4"×1.7"×1.0"  
71g/0.16lb



Emitter:  
145×35×25mm  
5.7"×1.38"×0.98"  
87g/0.2lb



ACCESSORIES

Sender/Receiver/  
Battery



2x9V 6F22  
Batteries



Calibration  
Certificate



Quick  
Start Guide

**PACKAGING INFORMATION**



**Color Box**  
L125×W40×H255mm



**Carton Box**  
53x22x27cm



**X 20PCS**



**MAIN APPLICATIONS**

Fig.1 SHORT



Fig.2 MISWIRE



Fig.3 REVERSED



Fig.4 SPLIT PAIRS



**MULTI-FUNCTIONS CABLE TRACKER**  
**MS6813**

SKU NO: MS6813CBGLO  
UPC CODE: 810053672976  
EAN CODE: 8435394778709

**FEATURE**

- Multifunction.
- Cable tester and tracker.
- State of the telephone lines.
- Small size ideal for transport.

**SPECIFICATIONS**

Receive Frequency  
**100Hz~300kHz**

Send Tone Frequency  
**1-5kHz**

**CONTENTS**



206×84×55mm  
8.1"×3.3"×2.1"  
330g/0.72lb



2×9V 6F22  
Batteries



Carry bag/Sender/Receiver  
Battery

**ACCESSORIES**



Calibration  
Certificate



Quick  
Start Guide

**PACKAGING INFORMATION**



Color Box  
L172×W80×H245mm



Carton Box  
46×27×37cm



X 10PCS



**MAIN APPLICATIONS**

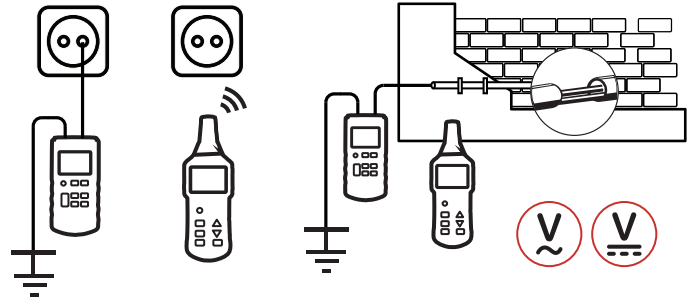

**CONTENTS**



Transmitter:  
190×89×42.5mm  
7.48"×3.5"×1.67"  
420g/0.92lb



Receiver:  
241.5×78×38.5mm  
9.5"×3"×1.5"  
350g/0.77lb



ACCESSORIES

Test leads/Test probe/  
Alligator clip/Grounding  
rod/Package bag/  
Battery



1×9V 6F22 Battery/  
6×1.5V AAA Batteries



Calibration  
Certificate



Quick  
Start Guide

**ADVANCED WIRE TRACKER**  
**MS6818**

SKU NO: MS6818CBGLO  
UPC CODE: 810053672204  
EAN CODE: 8435394777924

**FEATURE**

- Track Cables In The Wall or Earth.
- Find The Fuse And Safeguard.
- Find The Breaks Or Shorts In Conduit Under The Floor.

**SPECIFICATIONS**

AC Voltage <b>400V</b>	DC Voltage <b>400V</b>	Output Signal <b>125kHz</b>
Display Counts <b>2000</b>		

**PACKAGING INFORMATION**



**Color Box**  
L200xW85xH280mm



**Carton Box**  
44.5x32.5x42cm



**X 10PCS**

# EARTH RESISTANCE

EARTH RESISTANCE CLAMP METER | EARTH RESISTANCE TESTER  
ADVANCED EARTH RESISTANCE TESTER







### MAIN APPLICATIONS

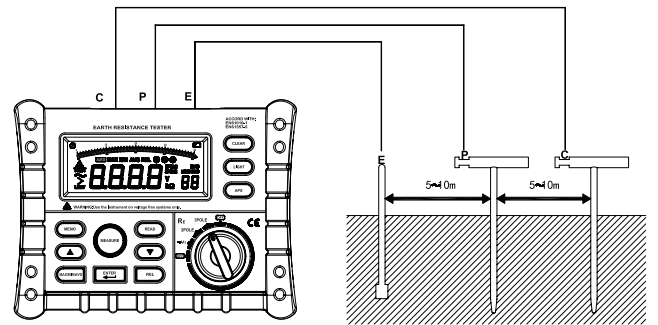
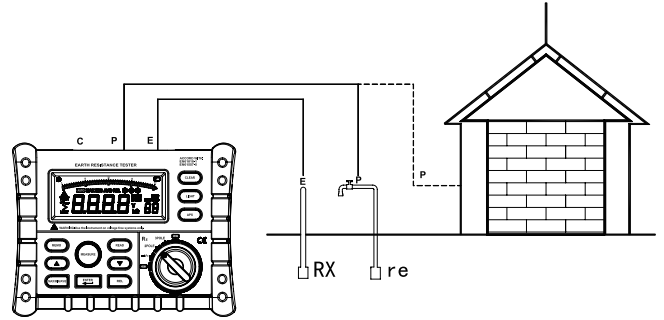

## EARTH RESISTANCE TESTER MS2302

SKU NO: MS2302CBGLO  
UPC CODE: 810053672150  
EAN CODE: 8435394777870

### FEATURE

- Auto & Manual Ranging
- Auto Power Off
- Segments Bar Graph
- MAX/MIN/AVG.

### SPECIFICATIONS

Earth Voltage  
**AC 0~200V**

Earth Resistance  
**0.01~4000Ω**

### CONTENTS

330×265×125mm  
13"×10.4"×4.9"  
900g/1.98lb

6×1.5V AA  
Batteries

**ACCESSORIES** Test leads (Red-15m, Green-10m, Black-5m)/  
Wrapping bag/Auxiliary earth bar/Battery

Calibration  
Certificate

**QSG** Quick  
Start Guide

### PACKAGING INFORMATION

**Color Box**  
L325×W125×H255mm

**Carton Box**  
52×33.5×29cm

**X 4PCS**



# ADVANCED EARTH RESISTANCE TESTER MS2306

SKU NO: MS2306CTGLO  
UPC CODE: 810053675069  
EAN CODE: 8435394783079

## FEATURE

- Auto Power Off.
- Alarming indicator for limit-value measurement.
- AVG.
- Compensation Resistance.

## SPECIFICATIONS

AC Voltage <b>20V</b>	DC Current <b>3 Pole &amp; 4 Pole AC48V/20kΩ</b>
Resistance <b>30/150/20kΩ</b>	

## MAIN APPLICATIONS

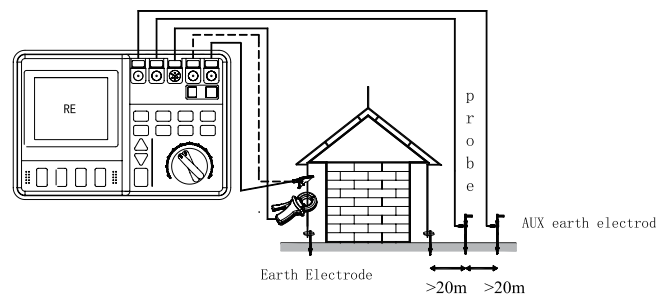
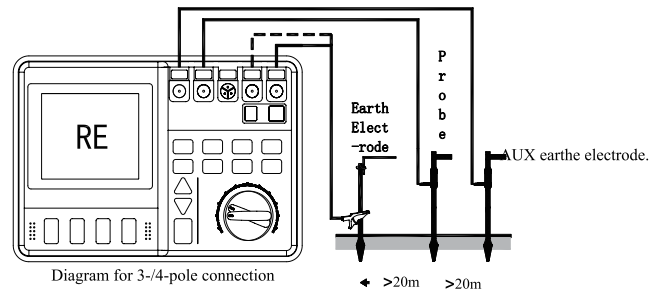

## CONTENTS



284×230×125mm  
11.2"×9.1"×4.9"  
2.5kg/5.5lb



6×1.5V AA  
Batteries/  
Ni~MH Recharge  
Battery, 7.2V



ACCESSORIES

Test wire/Alligator clip/Auxiliary earth bar/Power cord/Carry bag/Rechargeable Ni-MH battery (optional)/Charger (Optional)/Battery



Calibration  
Certificate



Quick  
Start Guide

## PACKAGING INFORMATION



Carton Box  
40×17.5×31.5cm



X 1PCS



**ADVANCED EARTH RESISTANCE TESTER**  
**MS2308**

SKU NO: MS2308CTGLO  
 UPC CODE: 810053676790  
 EAN CODE: 8435394785318

**FEATURE**

- Auto Power Off.
- Alarming indicator for limit-value measurement.
- AVG.
- Compensation Resistance.

**SPECIFICATIONS**

Earth Voltage  
**AC 0~48V**

Earth Resistance  
**0.02~300kΩ**

**MAIN APPLICATIONS**

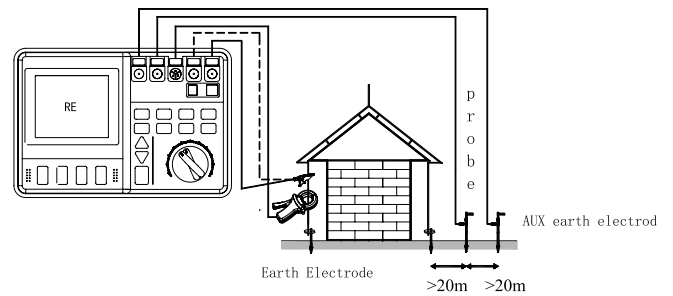
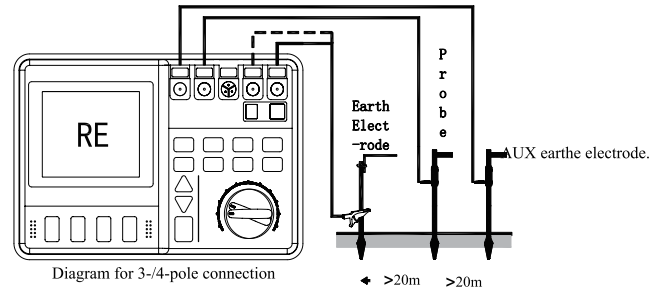

**CONTENTS**



284×230×125mm  
 11.2"×9.1"×4.9"  
 2.5kg/5.5lb



6×1.5V AA  
 Batteries/  
 Ni~MH Recharge  
 Battery, 7.2V



ACCESSORIES

Test wire/Alligator clip/Auxiliary earth bar/Power cord/ Current Transformer  $\phi$  51mm/ Current clamp cable/Carry bag/Software CD /Battery/ Rechargeable Ni-MH battery (optional)/Charger (Optional)/USB interface cable



Calibration  
 Certificate



Quick  
 Start Guide

**PACKAGING INFORMATION**



Carton Box  
 40×17.5×31.5cm



X 1PCS

# LCR METERS

DIGITAL LCR METER | SMART SMD TESTER





**MAIN APPLICATIONS**

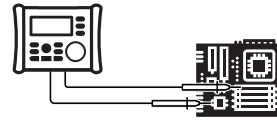

**CONTENTS**



224x172x58mm  
8.8"x6.8"x2.3"  
841g/1.85lb



8x1.5 AA  
Batteries



Kelvin test clip/SMD test probe/IR data/  
lineSoftware CD/External power supply (option)

**ACCESSORIES**



Calibration  
Certificate



Quick  
Start Guide

**DIGITAL LCR METER WITH USB  
INTERFACE**

**MS5308**

SKU NO: MS5308CBGLO  
UPC CODE: 810053673102  
EAN CODE: 8435394778839

**FEATURE**

- Auto & Manual Ranging.
- Auto Power off.
- LCR smart check and measurement.
- DCR mode.

**SPECIFICATIONS**

Resistance  
**200MΩ**

Capacitance  
**20mF**

LCR  
**20kHz**

**PACKAGING INFORMATION**



**Color Box**  
L320xW125xH255mm



**Carton Box**  
52x33.5x29cm



**X 4PCS**



**MAIN APPLICATIONS**

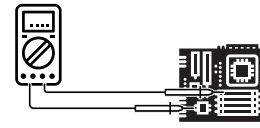

**CONTENTS**



189×91×31.5mm  
7.4"×3.6"×1.2"  
240g/0.52lb



1×9V 6F22  
Battery



ACCESSORIES

Holster/Test Leads/  
Battery



Calibration  
Certificate



Quick  
Start Guide

**DIGITAL LCR METER**

**MS6013**

SKU NO: MS6013CBGLO  
UPC CODE: 810053674222  
EAN CODE: 8435394779294

**FEATURE**

- Zero Adjustment approx. ± 20pF.
- Input Jacks.
- High Accuracy in Measuring.
- Low Battery Display.

**SPECIFICATIONS**

Inductance  
**2mH~2H**

Capacitance  
**200pF~20mF**

Display Counts  
**2000**

**PACKAGING INFORMATION**



**Color Box**  
L165×W70×H225mm



**Carton Box**  
47×37.5×35.5cm



**X 20PCS**



**MAIN APPLICATIONS**

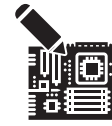

**SMART SMD TESTER (R/C)**  
**MS8910**

SKU NO: MS8910CBGLO  
UPC CODE: 810053672747  
EAN CODE: 8435394778389

**FEATURE**

- Auto Ranging.
- Auto Power Off.
- Data Hold.
- Low Battery Display.

**SPECIFICATIONS**

Resistance <b>30MΩ</b>	Capacitance <b>30mF</b>	Display Counts <b>3000</b>
Continuity <b>30Ω</b>		

**CONTENTS**

- 175x32x20mm  
6.89"x1.26"x0.79"  
48g/0.10lb
- 1x3V CR2032 Battery
- Spare test pin/Wrapping case/  
Battery
- Calibration Certificate
- Quick Start Guide

**PACKAGING INFORMATION**

- Color Box**  
L57xW29xH203mm
- Carton Box**  
44x32x31.5cm
- X 100PCS**



**MAIN APPLICATIONS**

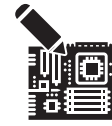

**CONTENTS**



186×35×23.6mm  
7.3"×1.38"×0.93"  
90g/0.2lb



1×3V CR2450  
Battery



**ACCESSORIES**

Battery



Calibration  
Certificate



Quick  
Start Guide

**SMART SMD TESTER (R/C/L)**  
**MS8911**

SKU NO: MS8911CBGLO  
UPC CODE: 810053674512  
EAN CODE: 8435394779584

**FEATURE**

- Auto Ranging.
- Auto Power Off.
- Data Hold.
- Low Battery Display.

**SPECIFICATIONS**

Resistance  
**20MΩ**

Capacitance  
**6mF**

Inductance  
**200H**

Display Counts  
**6000**

**PACKAGING INFORMATION**



**Color Box**  
L57×W29×H203mm



**Carton Box**  
44×32×31.5cm



**X 100PCS**





**MAIN APPLICATIONS**

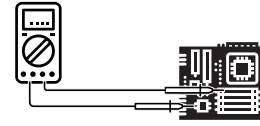

**CONTENTS**



189×91×31.5mm  
7.4"×3.6"×1.2"  
240g/0.52lb



1×9V 6F22  
Battery



ACCESSORIES

Test Leads/Holster/  
Battery



Calibration  
Certificate



Quick  
Start Guide

**DIGITAL LC METER**

**MY6243**

SKU NO: MY6243CBGLO  
UPC CODE: 810053672754  
EAN CODE: 8435394778396

**FEATURE**

- Input Jacks.
- High Accuracy in Measuring.
- Low Battery Display.

**SPECIFICATIONS**

Capacitance  
**200µF**

Inductance  
**2H**

Display Counts  
**2000**

**PACKAGING INFORMATION**



**Color Box**  
L165×W70×H225mm



**Carton Box**  
47×37.5×35.5cm



**X 20PCS**

# INSULATION TESTERS

DIGITAL INSULATION TESTER | HIGH VOLTAGE DIGITAL INSULATION TESTER | ADVANCED HIGH VOLTAGE INSULATION TESTER





**MAIN APPLICATIONS**

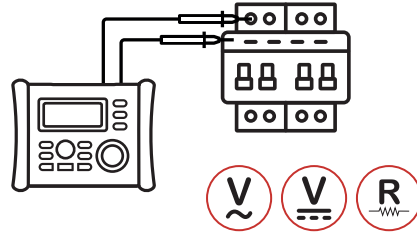

**CONTENTS**

- 200x155x76mm  
7.6"x5.9"x2.95"  
900g/1.98lb
- 6x1.5V AA Batteries
- ACCESSORIES**
  - Test Leads/Test Clips/Wrapping Bag/Battery
  - Calibration Certificate
  - Quick Start Guide

**DIGITAL INSULATION TESTER**  
**MS5203**

SKU NO: MS5203CBGLO  
UPC CODE: 810053672587  
EAN CODE: 8435394784328

**FEATURE**

- Auto Power Off.
- MIN/MAX/AVG.
- Compare Function.
- TIMER.

**SPECIFICATIONS**

AC Voltage <b>750V</b>	DC Voltage <b>1000V</b>	DC Output <b>1000V</b>
Resistance <b>20Ω</b>		

**PACKAGING INFORMATION**





- Color Box**  
L325xW125xH255mm
- Carton Box**  
52x33.5x29cm
- X 4PCS**

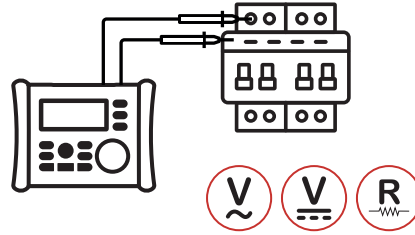

**MAIN APPLICATIONS**



**CONTENTS**

-  180×140×65mm  
7.1"×5.5"×2.56"  
900g/1.98lb
-  8×1.5V AA Batteries
-  **ACCESSORIES** Test Leads/Test Clips/Wrapping Bag/  
Battery
-  Calibration Certificate
-  **QSG** Quick Start Guide

**DIGITAL INSULATION TESTER**  
**MS5205**

SKU NO: MS5205CBGLO  
UPC CODE: 810053672907  
EAN CODE: 8435394778952



**FEATURE**

- Auto Power Off.
- LOCK.
- MIN/MAX/AVG.
- Compare Function.

**SPECIFICATIONS**

AC Voltage <b>750V</b>	DC Voltage <b>1000V</b>	DC Output <b>2500V</b>
Resistance <b>200Ω</b>		

**PACKAGING INFORMATION**

-  **Color Box**  
L325×W125×H255mm
-  **Carton Box**  
52×33.5×29cm
-  **X 4PCS**



**MAIN APPLICATIONS**

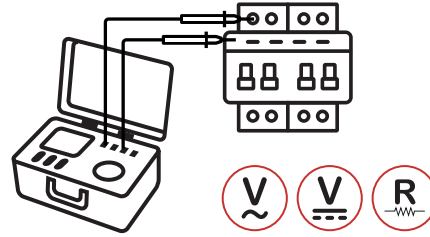

**CONTENTS**



284x230x125mm  
11.2"x9.1"x4.9"  
2426g/5.34lb



6xLr14 Batteries/  
6x1.2V AA  
Batteries



**ACCESSORIES**

Tester probes leads:  
3m x 3 (Red,Black,Blue)/  
Crocodile clip x 3  
(Red,Black,Blue)/  
Temperature Sensor/  
USB data line (1m)/Data  
Analysis Software CD/  
Instrument backpack/  
Rechargeable battery  
pack(for charging  
Ni-Hy battery)  
(Optional)/AC charger  
x 1" (Optional)/LR14  
alkaline batteries

Charger:  
Input Voltage  
100V~240V



Calibration  
Certificate



Quick  
Start Guide

**ADVANCED HIGH VOLTAGE  
INSULATION TESTER  
MS5215**

SKU NO: MS5215CBGLO  
UPC CODE: 810053672914  
EAN CODE: 8435394778648

**FEATURE**

- Broad Range Of Testing Voltage.
- Insulation Diagnosis.
- Large Storage Memory.
- Clear Display.

**SPECIFICATIONS**

AC Voltage  
**50~750V**

DC Voltage  
**50~1000V**

Resistance  
**0.01MΩ~5TΩ**

Temperature  
**-10~70°C/14~158°F**

**PACKAGING INFORMATION**



**Color Box**  
L400xW175xH315mm



**Carton Box**  
42x37x34cm



**X 2PCS**

# PAT TESTER

SAFETY PAT PLUS TESTER



**MASTECH**

EARTH CONT	> 8888.0 Ω	⚠	🔌
L-N × ✓	< 8888.0 MΩ	🔌	🔌
INSULATION	> 8888.0 MΩ	8888.0	
L-E × ✓	< 8888.0 mA~		
LEAKAGE	> 8888.0 mA~		
N-E × ✓			

**MS5911**  
**SAFETY PAT PLUS**  
300V CAT II

Ⓡ POWER Ⓢ

▲ ▼

**A** **B** **C**

CLASS I CLASS II DATA RECALL CORD / EXT

Yoshida YD 007S  
13A 250V  
BAYMAN  
3175  
EN1403





**MAIN APPLICATIONS**

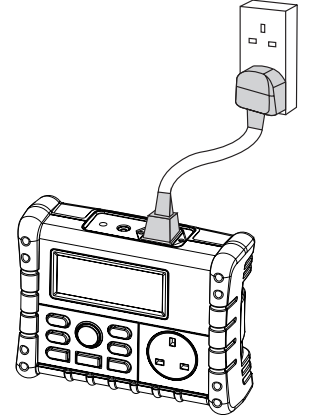
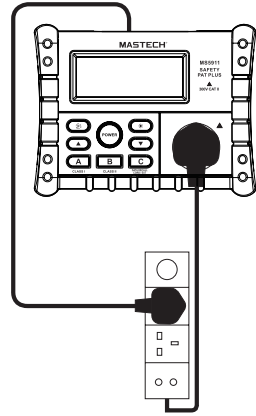
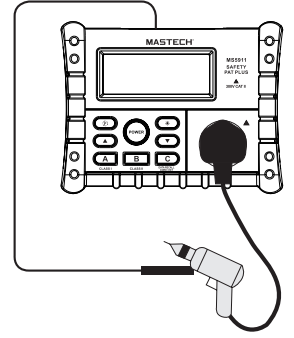
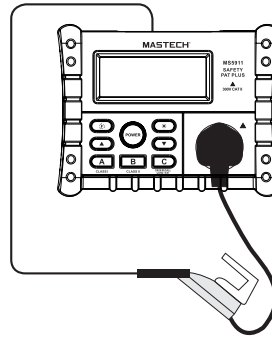

**SAFETY PAT PLUS TESTER**  
**MS5911**

SKU NO: MS5911CBGLO  
UPC CODE: 810053675137  
EAN CODE: 8435394783123

**FEATURE**

- Safety CLASS I - Grounding/Insulation Resistance/Leakage Current.
- Safety CLASS II - Insulation Resistance/Leakage Current .

**SPECIFICATIONS**

DC Output <b>250/500V</b>	Resistance <b>20MΩ</b>
------------------------------	---------------------------

**CONTENTS**

- |  |   |  |                                    |
|--|---|--|------------------------------------|
|  | 204x155x76mm<br>7.8"x6.1"x3"<br>1270g/2.8lb   |  | DV12V or<br>8x1.5V AA<br>Batteries |
|  | Main test cord/Alligator clip test cord/Probe/<br>Rugged padded carrying case/Battery/<br>DC power adapter (optional) |  | Calibration<br>Certificate         |
|  |   |  | Quick<br>Start Guide               |

**PACKAGING INFORMATION**

- |  |                                      |        |
|--|--------------------------------------|--------|
|  | <b>Color Box</b><br>L325xW125xH255mm |        |
|  | <b>Carton Box</b><br>52x33.5x29cm    | X 4PCS |

# THERMOMETERS

DIGITAL THERMOMETER | DIGITAL THERMO-HYGROMETER  
NON-CONTACT INFRARED THERMOMETER







**MAIN APPLICATIONS**

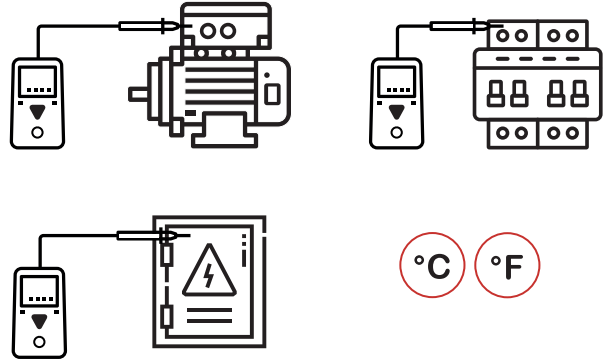

**CONTENTS**



125.5x72x27mm  
5.6"x2.8"x1.0"  
145g/0.30lb



1x9V 6F22  
Battery



ACCESSORIES

K type thermocouple/Carry bag  
Battery



Calibration  
Certificate



Quick  
Start Guide

**DIGITAL THERMOMETER**

**MS6500**

SKU NO: MS6500CBGLO  
UPC CODE: 810053673089  
EAN CODE: 8435394778815

**FEATURE**

- Sample Rate 500mS.
- Display 2000 counts.
- Data Hold.
- K-Type Thermocouple.

**SPECIFICATIONS**

Celsius Ranging.  
**-50°C~750°C**

Fahrenheit  
**-58°F~1382°F**

Display Counts  
**2000**

**PACKAGING INFORMATION**



**Color Box**  
L105xW40xH145mm



**Carton Box**  
42x31.5x34cm



**X 60PCS**



**DIGITAL THERMO-HYGROMETER**  
**MS6505**

SKU NO: MS6505CBGLO  
UPC CODE: 810053675229  
EAN CODE: 8435394783222

**FEATURE**

- Auto Power Off.
- MAX/MIN.
- Clock.
- Data logging 16300 groups.

**SPECIFICATIONS**

Temperature  
**-20~60°C/-4°F~140°F**

Display Counts  
**2000**

**MAIN APPLICATIONS**

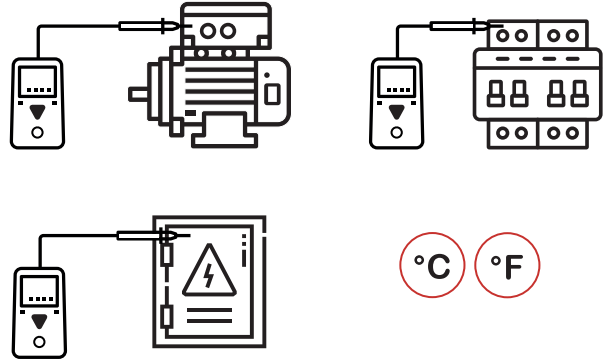

**CONTENTS**

183×74×42mm  
7.3"×2.9"×1.6"  
330g/0.7lb

1×9V 6F22  
Battery

**+** RS232 Date Line/Software CD/Carry bag/  
AC adapter/Battery  
**ACCESSORIES**

Calibration Certificate

**QSG** Quick Start Guide

**PACKAGING INFORMATION**

**Color Box**  
L172×W80×H255mm

**Carton Box**  
53×44.5×37cm

**X 20PCS**



**MAIN APPLICATIONS**

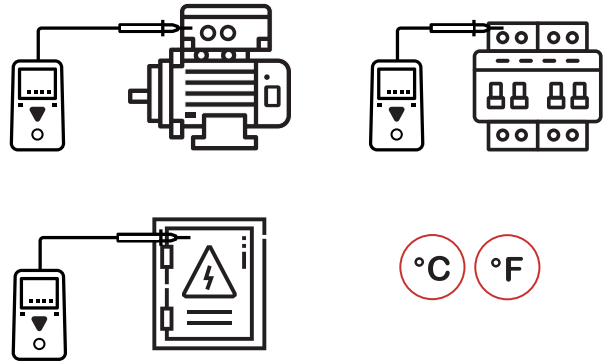

**DIGITAL THERMOMETER**  
**MS6511**

SKU NO: MS6511CBGLO  
UPC CODE: 810053675243  
EAN CODE: 8435394783246

**FEATURE**

- Auto Power Off.
- Data Hold.
- MAX/MIN/AVG.
- Low Battery Display.

**SPECIFICATIONS**

Type <b>K, J, T, E</b>	Channel <b>TC</b>
---------------------------	----------------------

**CONTENTS**

	190×89×42mm 7.5"×3.5"×1.7" 350g/0.8lb		1×9V 6F22 Battery
--	---	--	----------------------

K type thermocouple/  
Battery  
**ACCESSORIES**

	Calibration Certificate		Quick Start Guide
--	----------------------------	--	----------------------

**PACKAGING INFORMATION**

**Color Box**  
L165×W70×H225mm

**Carton Box**  
47×37.5×35.5cm

**X 20PCS**



**MAIN APPLICATIONS**

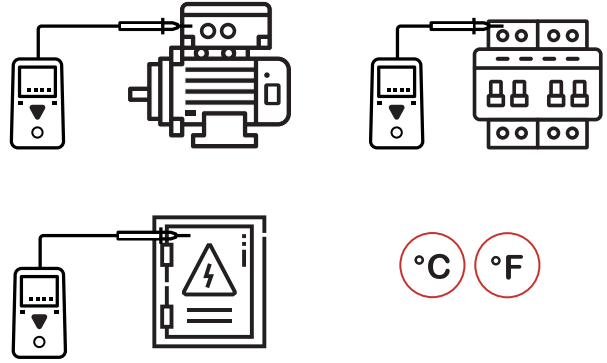

**DIGITAL THERMOMETER**  
**MS6512**

SKU NO: MS6512CBGLO  
UPC CODE: 810053672945  
EAN CODE: 8435394778679

**FEATURE**

- Auto Power Off.
- Data Hold.
- MAX/MIN/AVG.
- Low Battery Display.

**SPECIFICATIONS**

Type <b>K, J, T, E</b>	Channel <b>T1/T2/T1-T2</b>
---------------------------	-------------------------------

**CONTENTS**

190×89×42mm  
7.5"×3.5"×1.7"  
350g/0.8lb

1×9V 6F22  
Battery

K type thermocouple/  
Battery

**ACCESSORIES**

Calibration  
Certificate

**QSG** Quick  
Start Guide

**PACKAGING INFORMATION**

**Color Box**  
L165×W70×H225mm

**Carton Box**  
47×37.5×35.5cm

**X 20PCS**



**MAIN APPLICATIONS**

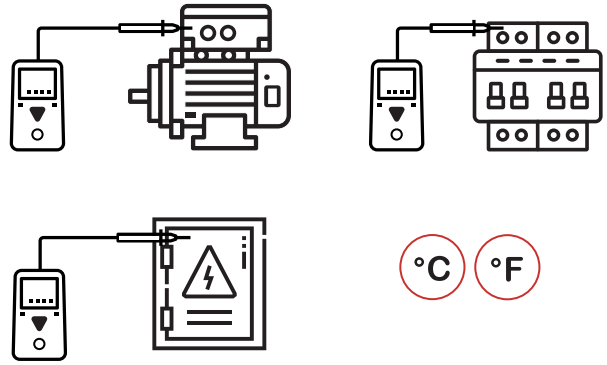

DIGITAL THERMOMETER  
**MS6513**

SKU NO: MS6513CBGLO  
UPC CODE: 810053672044  
EAN CODE: 8435394783253

**FEATURE**

- Auto Power Off.
- Data Hold.
- Memory Save Data.
- USB Interface.

**SPECIFICATIONS**

Type <b>K, J, T, E, R, S, N</b>	Channel <b>TC</b>
------------------------------------	----------------------

**CONTENTS**

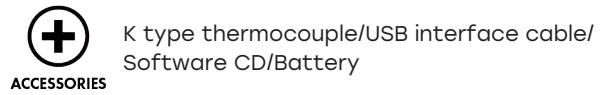
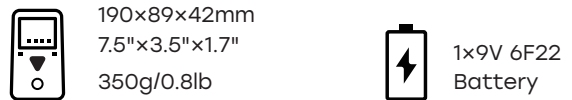

**PACKAGING INFORMATION**

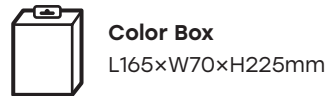



**MAIN APPLICATIONS**

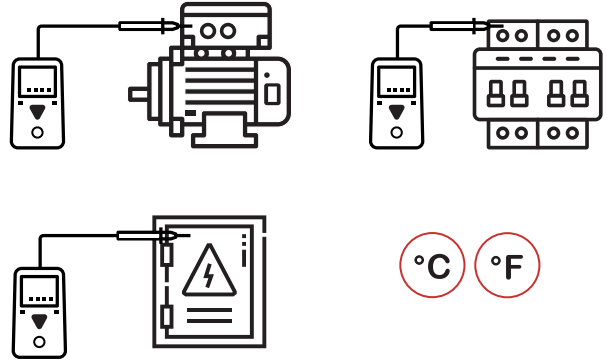

**DIGITAL THERMOMETER**

**MS6514**

SKU NO: MS6514CBGLO  
 UPC CODE: 810053672037  
 EAN CODE: 8435394777764

**FEATURE**

- Auto Power Off.
- Data Hold.
- Memory Save Data.
- USB Interface.

**SPECIFICATIONS**

Type  
**K, J, T, E, R, S, N**

Channel  
**T1/T2/T1-T2**

**CONTENTS**

190×89×42mm  
 7.5"×3.5"×1.7"  
 350g/0.8lb

1×9V 6F22  
 Battery

**+** K type thermocouple/USB interface cable/  
 Software CD/Battery  
**ACCESSORIES**

Calibration Certificate

QSG Quick Start Guide

**PACKAGING INFORMATION**

**Color Box**  
 L165×W70×H225mm

**Carton Box**  
 47×37.5×35.5cm

**X 20PCS**



INFRARED THERMOMETER  
**MS6522A**

SKU NO: MS6522ACBGLO  
UPC CODE: 810053674567  
EAN CODE: 8435394779638

**FEATURE**

- Spectral Response 8-14 μm.
- Laser <1mW/630-670nm.
- Response Time 1 Second.
- Relative Humidity 10%~90%

**SPECIFICATIONS**

Repeatability  
**±0.1°C**

Temperature  
**-20~300°C/-4~572°F**

Emissivity  
**0.95**

**MAIN APPLICATIONS**

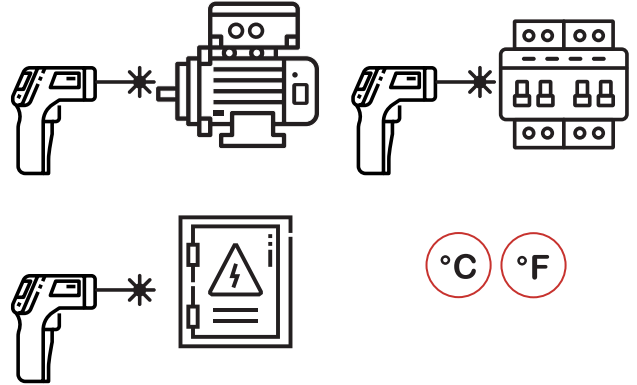

**CONTENTS**

 143×99×47mm  
5.6"×3.9"×1.85"  
135g/0.3lb

 2x1.5V AAA  
Batteries

 Battery  
**ACCESSORIES**

 Calibration  
Certificate

 Quick  
Start Guide

**PACKAGING INFORMATION**

 **Color Box**  
L125×W55×H183mm

 **Carton Box**  
57.5×39.1×27.5cm

 **X 40PCS**



**MAIN APPLICATIONS**

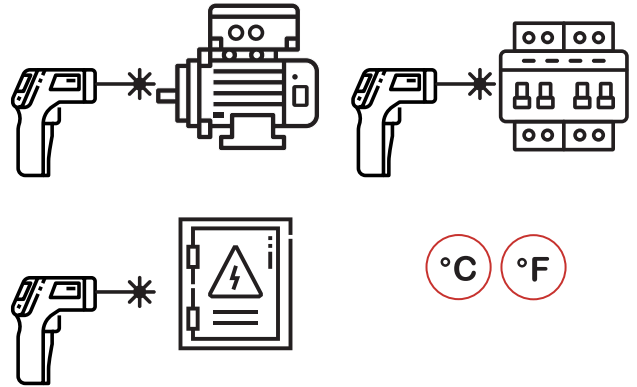

**INFRARED THERMOMETER**  
**MS6522B**

SKU NO: MS6522BCBGLO  
UPC CODE: 810053672617  
EAN CODE: 8435394778914

**FEATURE**

- Spectral Response 8-14 μm.
- Laser <1mW/630-670nm.
- Response Time 1 second.
- Relative Humidity 10%~90%

**SPECIFICATIONS**

Repeatability  
**±0.1°C**

Temperature  
**-20~500°C/-4~932°F**

Emissivity  
**0.95**

**CONTENTS**

143×99×47mm  
5.6"×3.9"×1.85"  
135g/0.3lb

2x1.5V AAA  
Batteries

Battery  
**ACCESSORIES**

Calibration  
Certificate

Quick  
Start Guide

**PACKAGING INFORMATION**

**Color Box**  
L125×W55×H183mm

**Carton Box**  
57.5×39.1×27.5cm

**X 40PCS**





**MAIN APPLICATIONS**

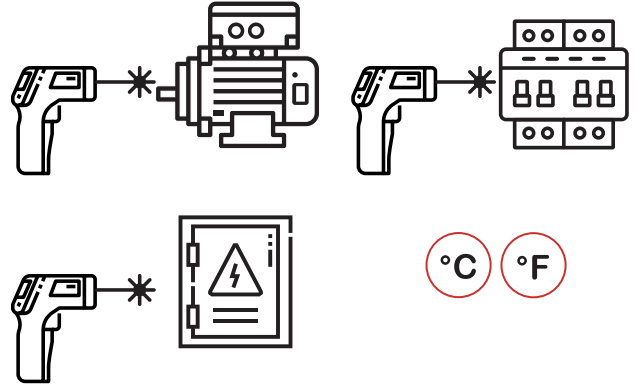

**INFRARED THERMOMETER COLOR LCD**  
**MS6531B**

SKU NO: MS6531BCBGLO  
UPC CODE: 810053672969  
EAN CODE: 8435394778693

**FEATURE**

- Color Display.
- Auto Power Off.
- Spectral Response 8-14  $\mu$ m.
- Laser <1mW/630-670nm.

**SPECIFICATIONS**

IRT Temperature <b>-40~800°C/-40~1472°F</b>	Repeatability <b>±0.1°C</b>
K-Type Temperature <b>-40~1080°C/-40~1976°F</b>	Emissivity <b>0.10~1.00</b>

**CONTENTS**

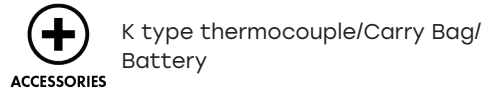
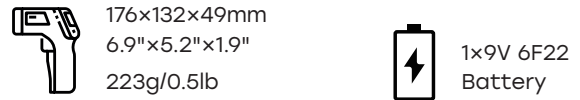

**PACKAGING INFORMATION**

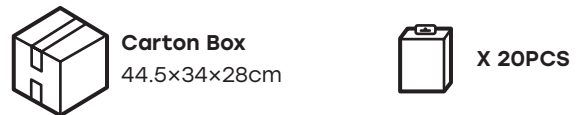
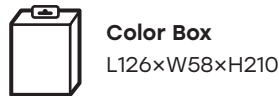



**MAIN APPLICATIONS**

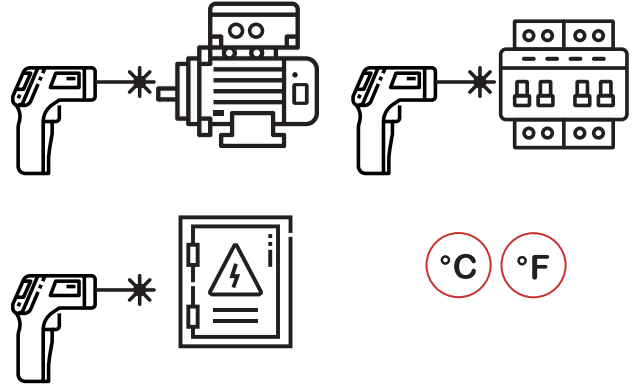

INFRARED THERMOMETER COLOR LCD  
**MS6531C**

SKU NO: MS6531CCBGLO  
UPC CODE: 810053674284  
EAN CODE: 8435394779355

**FEATURE**

- Color Display.
- Auto Power Off.
- Spectral Response 8-14 μm.
- Laser <1mW/630-670nm.

**SPECIFICATIONS**

IRT Temperature <b>-40~800°C/-40~1472°F</b>	Repeatability <b>±0.1°C</b>
K-Type Temperature <b>-40~1080°C/-40~1976°F</b>	Emissivity <b>0.10~1.00</b>

**CONTENTS**

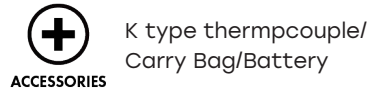
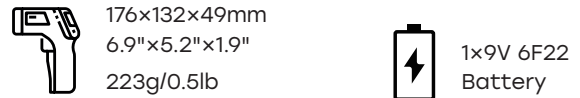

**PACKAGING INFORMATION**

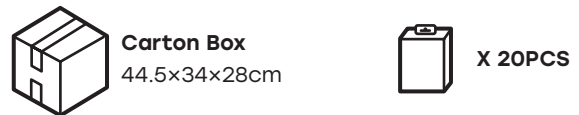
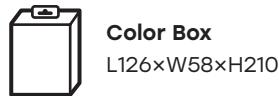



**INFRARED THERMOMETER**  
**MS6541**

SKU NO: MS6541CBGLO  
UPC CODE: 810053674291  
EAN CODE: 8435394779362

**FEATURE**

- Color Display.
- Auto Power Off.
- Spectral Response 8-14 μm.
- Laser <1mW/630-670nm.

**SPECIFICATIONS**

IRT Temperature  
**-20~350°C/-4~662°F**

Repeatability  
**±0.1°C**

K-Type Temperature  
**-50~300°C/-58~572°F**

Emissivity  
**0.10~1.00**

**MAIN APPLICATIONS**

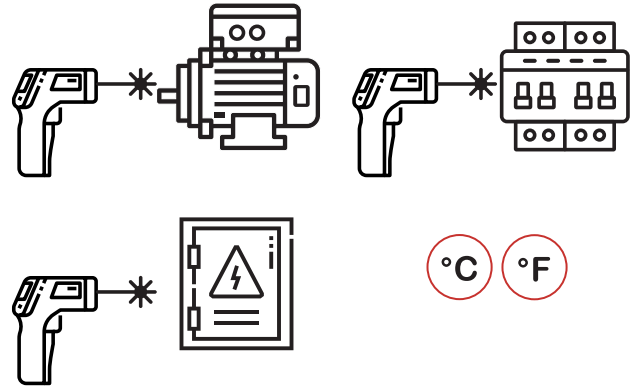

**CONTENTS**

192×95×83mm  
7.5"×3.7"×3.3"  
275g/0.6lb

1×9V 6F22  
Battery

K type thermocouple/Carry Bag/  
Battery  
**ACCESSORIES**

Calibration  
Certificate

**QSG** Quick  
Start Guide

**PACKAGING INFORMATION**

**Color Box**  
L126×W58×H210mm

**Carton Box**  
44.5×34×28cm

**X 20PCS**

# ENVIRONMENTAL METERS

SOUND LEVEL METER | ANEMOMETER | LIGHT METER  
MOISTURE TESTER | TACHOMETERS | GAS DETECTOR  
MULTI-FUNCTIONS ENVIRONMENT TESTER  
ELECTRONIC STUD METAL FINDER | VOLTAGE AND CURRENT  
CALIBRATOR





DIGITAL SOUND LEVEL METER  
**MS6700**

SKU NO: MS6700CBGLO  
UPC CODE: 810053676691  
EAN CODE: 8435394784779

**FEATURE**

- Auto & Manual Ranging.
- Auto Power Off.
- Dynamic 50dB.
- Frequency 30Hz~8kHz.

**SPECIFICATIONS**

Sound Level <b>30dB~130dB</b>	Frequency <b>31.5Hz~8KHz</b>	Dynamic <b>50dB</b>
Display Counts <b>2000</b>		

**MAIN APPLICATIONS**

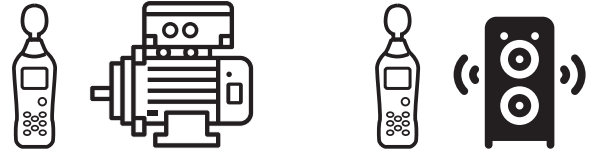

**CONTENTS**



265x80x69mm  
10.4"x3.15"x2.7"  
317g/0.7lb



6x1.5V AAA  
Batteries



ACCESSORIES

Windscreen/Earphone plug/Wapping case/  
Battery



Calibration  
Certificate



Quick  
Start Guide

**PACKAGING INFORMATION**



**Color Box**  
L160xW74xH295mm



**Carton Box**  
38.5x32x34cm



**X 10PCS**



**MAIN APPLICATIONS**

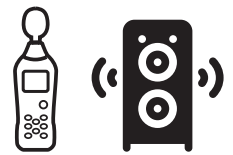
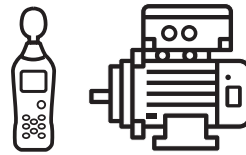

**DIGITAL SOUND LEVEL METER**  
**MS6701**

SKU NO: MS6701CBGLO  
UPC CODE: 810053674321  
EAN CODE: 8435394779393

**FEATURE**

- Auto & Manual Ranging.
- Auto Power Off.
- Dynamic 50dB.
- Frequency 30Hz~8kHz.

**SPECIFICATIONS**

Sound Level <b>30dB~130dB</b>	Frequency <b>31.5Hz~8KHz</b>	Dynamic <b>50dB</b>
Display Counts <b>2000</b>		

**CONTENTS**



265×80×69mm  
10.4"×3.15"×2.7"  
317g/0.7lb



6×1.5V AAA  
Batteries



**ACCESSORIES**

Windscreen/Earphone plug/Wapping case/  
RS232 interface cable/Software CD/Battery



Calibration  
Certificate



Quick  
Start Guide

**PACKAGING INFORMATION**



**Color Box**  
L160×W74×H295mm



**Carton Box**  
38.5×32×34cm



**X 10PCS**



**MAIN APPLICATIONS**

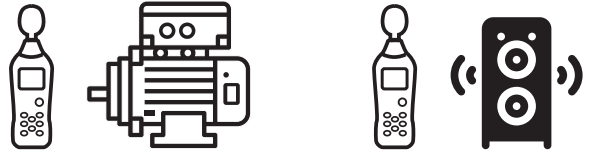

**DIGITAL SOUND LEVEL METER**  
**MS6708**

SKU NO: MS6708CBGLO  
UPC CODE: 810053674338  
EAN CODE: 8435394779409

**FEATURE**

- Auto & Manual Ranging.
- Auto Power Off.
- Dynamic 50dB.
- Frequency 30Hz~8kHz.

**SPECIFICATIONS**

Sound Level <b>30dB~130dB</b>	Frequency <b>31.5Hz~8KHz</b>	Dynamic <b>50dB</b>
Display Counts <b>2000</b>		

**CONTENTS**



193×60×29mm  
7.6"×2.4"×1.1"  
222g/0.48lb



4×1.5V AAA  
Batteries



ACCESSORIES

Windscreen/Carry Bag/  
Battery



Calibration  
Certificate



Quick  
Start Guide

**PACKAGING INFORMATION**



**Color Box**  
L95×W45×H230mm



**Carton Box**  
49.5×27×41cm



**X 40PCS**



**MAIN APPLICATIONS**

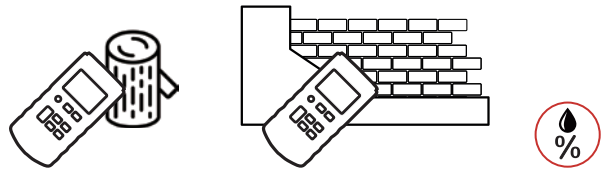

**CONTENTS**



130×56×29mm  
5.1"×2.2"×1.1"  
120g 0.26lb



2×1.5V AAA  
Batteries



Carry bag/  
Battery

**ACCESSORIES**



Calibration  
Certificate



Quick  
Start Guide

**PACKAGING INFORMATION**



**Color Box**  
L75×W55×H155mm



**Carton Box**  
61×33×25cm



**X 60PCS**

**MOISTURE TESTER**

**MS6900**

SKU NO: MS6900CBGLO  
UPC CODE: 810053674376  
EAN CODE: 8435394779447

**FEATURE**

- Verification Test Points.
- Depth 0~50mm.
- Sampling Rate 240ms.
- Unit Selection %, WB, TD, °C, °F, %RH.

**SPECIFICATIONS**

Material Moisture  
**0.0~60.0%**

Ambient TEMP  
**-10~50°C/14~122°F**

Relative Humidity  
**10~90%**





**MAIN APPLICATIONS**

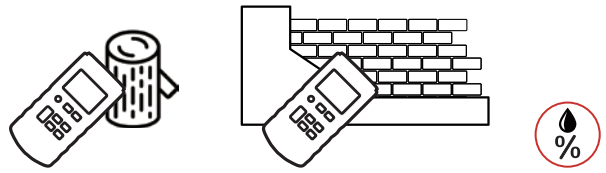

**CONTENTS**



130×56×29mm  
5.1"×2.2"×1.1"  
120g 0.26lb



2×1.5V AAA  
Batteries



Carry bag/  
Battery

**ACCESSORIES**



Calibration  
Certificate



Quick  
Start Guide

**PACKAGING INFORMATION**



**Color Box**  
L75×W55×H155mm



**Carton Box**  
61×33×25cm



**X 60PCS**

**MOISTURE TESTER**

**MS6900A**

SKU NO: MS6900ACBGLO  
UPC CODE: 810053675298  
EAN CODE: 8435394783314

**FEATURE**

- Verification Test Points.
- Depth 0~50mm.
- Sampling Rate 240ms.
- Unit Selection %, WB, TD, °C, °F, %RH.

**SPECIFICATIONS**

Material Moisture  
**0.0~60.0%**

Ambient TEMP  
**-10~50°C/14~122°F**

Relative Humidity  
**10~90%**



**MAIN APPLICATIONS**

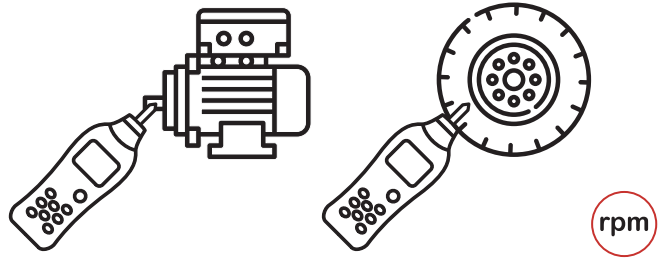

**CONTENTS**



170×60×27mm  
6.7"×2.4"×1.1"  
130g/0.28lb



4×1.5AAA  
Batteries



Measurement idler wheels/touch tips/  
lengthening bar/Carry bag/Battery

**ACCESSORIES**



Calibration  
Certificate



Quick  
Start Guide

**DIGITAL TACHOMETERS (Contact)**

**MS6208A**

SKU NO: MS6208ACBGLO  
UPC CODE: 810053672167  
EAN CODE: 8435394777887

**FEATURE**

- Contact Measuring Mode.
- Unit Selection m/min, m/sec, ft/min, ft/sec, in/min
- Auto Power Off.

**SPECIFICATIONS**

Ranging (contact)  
**50~19,999RPM**

**PACKAGING INFORMATION**



**Color Box**  
L95×W45×H195mm



**Carton Box**  
41.5×27×41cm



**X 40PCS**



**MAIN APPLICATIONS**

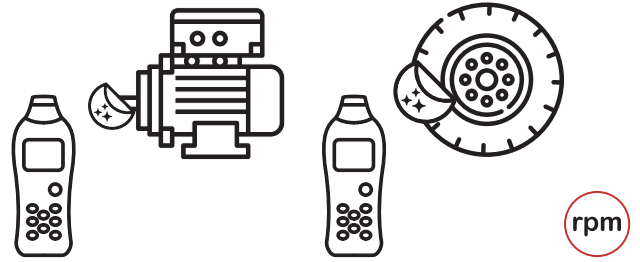

**CONTENTS**



155×60×27mm  
6.1"×2.4"×1.1"  
120g/0.26lb



4×1.5AAA  
Batteries



Reflective sheetin/Carry bag/  
Battery

**ACCESSORIES**



Calibration  
Certificate



Quick  
Start Guide

**DIGITAL TACHOMETERS (Non-Contact)**  
**MS6208B**

SKU NO: MS6208BCBGLO  
UPC CODE: 810053672174  
EAN CODE: 8435394777894

**FEATURE**

- Non-Contact Measuring Mode.
- Measuring Distance 50mm~250mm.
- Auto Power Off.
- MAX/MIN.

**SPECIFICATIONS**

Ranging (non-contact)  
**50~99,999 RPM**

**PACKAGING INFORMATION**



**Color Box**  
L95×W45×H195mm



**Carton Box**  
41.5×27×41cm



**X 40PCS**



**MAIN APPLICATIONS**

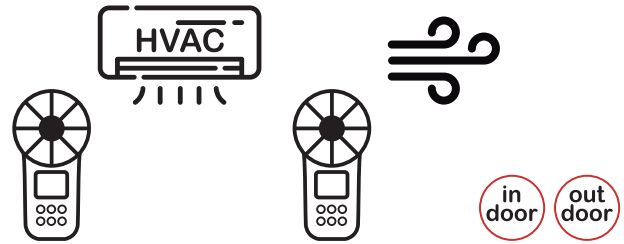

**CONTENTS**

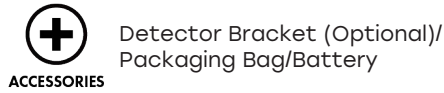
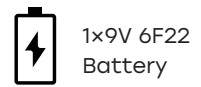
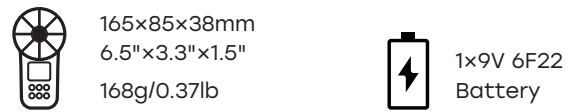

**PACKAGING INFORMATION**

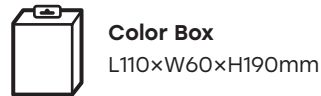

**DIGITAL ANEMOMETER**

**MS6252A**

SKU NO: MS6252ACBGLO  
 UPC CODE: 810053672181  
 EAN CODE: 8435394777900

**FEATURE**

- Auto Power Off.
- Flow Area Setting.
- MAX/MIN.
- Data Hold.

**SPECIFICATIONS**

CFM <b>999.9/9.999ft<sup>2</sup></b>	CMM <b>999.9/9.999m<sup>2</sup></b>	CMS <b>99.99/9.999m<sup>2</sup></b>
Display Counts <b>9999</b>		



**MAIN APPLICATIONS**

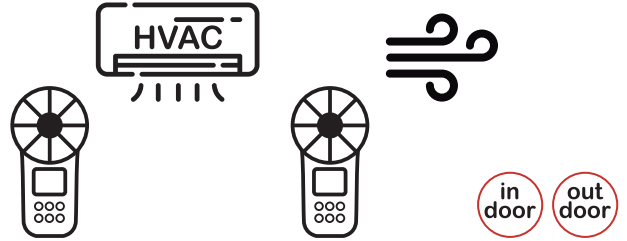

**CONTENTS**

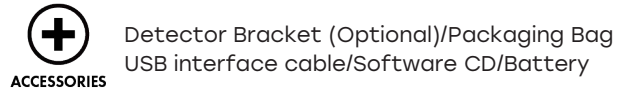
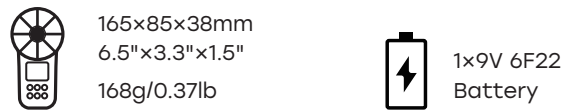

**DIGITAL ANEMOMETER**

**MS6252B**

SKU NO: MS6252BCBGLO  
 UPC CODE: 810053673096  
 EAN CODE: 8435394778822

**FEATURE**

- Auto Power Off.
- °C/°F Selection.
- Ambient.
- Dew Point.

**SPECIFICATIONS**

CFM <b>999.9/9.999ft<sup>2</sup></b>	CMM <b>999.9/9.999m<sup>2</sup></b>	CMS <b>99.99/9.999m<sup>2</sup></b>
Display Counts <b>9999</b>		

**PACKAGING INFORMATION**

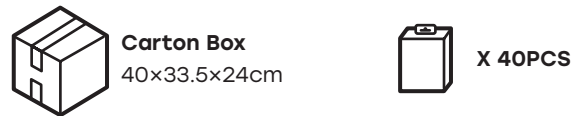
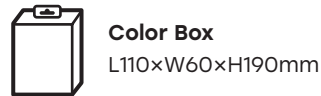



**MAIN APPLICATIONS**

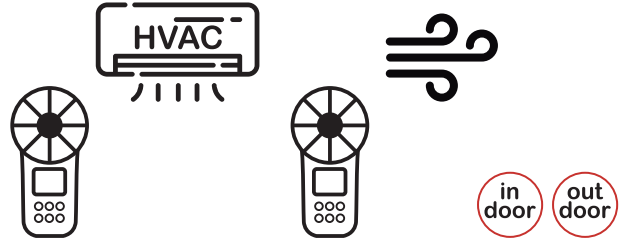

**CONTENTS**



165×85×38mm  
6.5"×3.3"×1.5"  
168g/0.37lb



1×9V 6F22  
Battery



ACCESSORIES

Detector Bracket (Optional)/  
Packaging Bag/Battery



Calibration  
Certificate



Quick  
Start Guide

**DIGITAL ANEMOMETER**

**MS6252D**

SKU NO: MS6252DCBGLO  
UPC CODE: 810053676813  
EAN CODE: 8435394785349

**FEATURE**

- Auto Power Off.
- °C/°F Selection.
- Ambient.
- Dew Point.

**SPECIFICATIONS**

CFM <b>999.9/9.999ft<sup>2</sup></b>	CMM <b>999.9/9.999m<sup>2</sup></b>	CMS <b>99.99/9.999m<sup>2</sup></b>
Display Counts <b>9999</b>		

**PACKAGING INFORMATION**



**Color Box**  
L110×W60×H190mm



**Carton Box**  
40×33.5×24cm



**X 40PCS**



**MAIN APPLICATIONS**



**CONTENTS**



172×70×465mm  
6.8"×2.8"×1.8"  
354g/0.78lb



4×1.5V AA  
Batteries



Carry bag/  
Battery

**ACCESSORIES**



Calibration  
Certificate



Quick  
Start Guide

**PACKAGING INFORMATION**



**Color Box**  
L130×W63×H255mm



**Carton Box**  
53×34×28.5cm



**X 20PCS**

**COMBUSTIBLE GAS DETECTOR**  
**MS6310**

SKU NO: MS6310CBGLO  
UPC CODE: 810053672334  
EAN CODE: 8435394778242

**FEATURE**

- Easy to Identify and Pinpoint Gas Leaks.
- Portable and High Sensitivity.
- Resume Original Measurement State After 7~10 Minutes in Clear Air.

**SPECIFICATIONS**

Resolution  
**50ppm**

Alarm  
**10%~40%**



**DIGITAL LIGHT METER [LUX]**  
**MS6610**

SKU NO: MS6610CBGLO  
UPC CODE: 810053673058  
EAN CODE: 8435394778785

**FEATURE**

- Data Hold.
- Silicon Photo Diode with Filter Photo Detector.
- Lead Length 150cm (Approx).
- Low Battery Indicator.

**SPECIFICATIONS**

LUX Ranging <b>50,000</b>	Display Counts <b>2000</b>
------------------------------	-------------------------------

**MAIN APPLICATIONS**

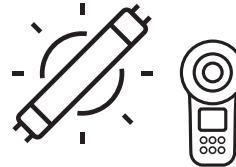
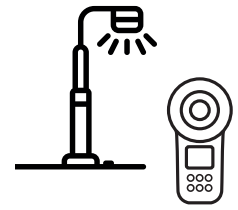
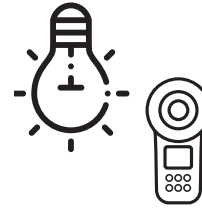

**CONTENTS**



126×72×27mm  
5.0"×2.8"×1.0"  
180g/0.4lb

Detector Size:  
83×52×21mm  
3.2"×2.0"×0.8"



Battery

ACCESSORIES



1×9V 6F22  
Battery



Calibration  
Certificate



Quick  
Start Guide

**PACKAGING INFORMATION**



**Color Box**  
L115×W55×H165mm



**Carton Box**  
48×34×31.5cm



**X 40PCS**





**MAIN APPLICATIONS**

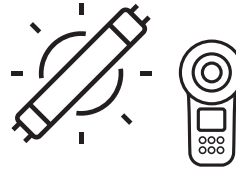
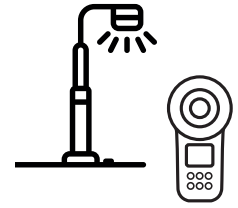
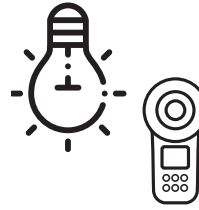

**DIGITAL LIGHTMETER [LUX/FC/CD]**  
**MS6612**

SKU NO: MS6612CBGLO  
UPC CODE: 810053674307  
EAN CODE: 8435394779379

**FEATURE**

- Relative Measurement.
- Peak Measurement.
- Zero Calibration.
- LUX, FC & CD unit selection.

**SPECIFICATIONS**

CD Ranging <b>999,900</b>	LUX Ranging <b>200,000</b>	FC Ranging <b>20,000</b>
Display Counts <b>2000</b>		

**CONTENTS**



170×89×43mm  
6.7"×3.5"×1.7"  
420g/0.93lb



1×9V 6F22  
Battery



ACCESSORIES

Carry bag/  
Battery



Calibration  
Certificate



Quick  
Start Guide

**PACKAGING INFORMATION**



**Color Box**  
L110×W60×H190mm



**Carton Box**  
40×33.5×24cm



**X 20PCS**



**MAIN APPLICATIONS**

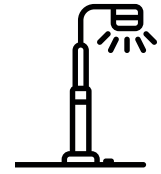

**DIGITAL LIGHTMETER [LUX/FC/CD]  
MS6612B**

SKU NO: MS6612BCBGLO  
UPC CODE: 810053674314  
EAN CODE: 8435394779386

**FEATURE**

- Relative Measurement.
- Peak Measurement.
- Zero Calibration.
- LUX, FC & CD unit selection.

**SPECIFICATIONS**

CD Ranging  
**999,900**

LUX Ranging  
**200,000**

FC Ranging  
**20,000**

Display Counts  
**2000**

**CONTENTS**



170×89×43mm  
6.7"×3.5"×1.7"  
420g/0.93lb



1×9V 6F22  
Battery



ACCESSORIES

Carry bag/  
Battery



Calibration  
Certificate



Quick  
Start Guide

**PACKAGING INFORMATION**



Color Box  
L110×W60×H190mm



Carton Box  
40×33.5×24cm



X 20PCS



**MAIN APPLICATIONS**

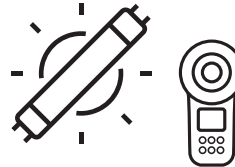
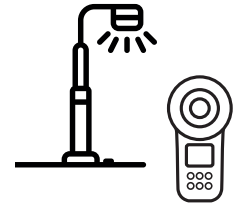
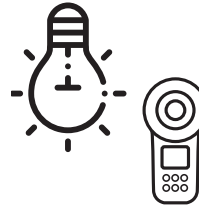

**DIGITAL LIGHTMETER [LUX/FC/CD]  
MS6612D**

SKU NO: MS6612DCBGLO  
UPC CODE: 810053676820  
EAN CODE: 8435394785356

**FEATURE**

- Relative Measurement.
- Peak Measurement.
- Zero Calibration.
- LUX, FC & CD unit selection.

**SPECIFICATIONS**

CD Ranging <b>999,900</b>	LUX Ranging <b>200,000</b>	FC Ranging <b>20,000</b>
Display Counts <b>2000</b>		

**CONTENTS**



170×89×43mm  
6.7"×3.5"×1.7"  
420g/0.93lb



1×9V 6F22  
Battery



ACCESSORIES

Carry bag/  
Battery



Calibration  
Certificate



Quick  
Start Guide

**PACKAGING INFORMATION**



**Color Box**  
L110×W60×H190mm



**Carton Box**  
40×33.5×24cm



**X 20PCS**



**MAIN APPLICATIONS**

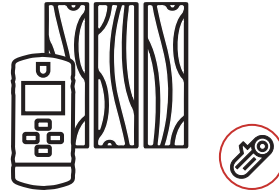

**CONTENTS**



160x74x42mm  
6.3"x2.9"x1.65"  
154g/0.33lb



1x9V 6F22  
Battery



Calibration  
Certificate



Quick  
Start Guide

**PACKAGING INFORMATION**



**Color Box**  
L145xW60xH188mm



**Carton Box**  
40x32x31.5cm



**X 20PCS**

**ELECTRONIC STUD METAL FINDER**  
**MS6906**

SKU NO: MS6906CBGLO  
UPC CODE: 810053674574  
EAN CODE: 8435394779645

**FEATURE**

- Auto Power Off.
- Low Battery Display.
- Display Backlight, Work Light.

**SPECIFICATIONS**

Wooden Pillar  
**30mm**

Metal Stud Detection Detph  
**30/50mm**

AC Voltage Detection Detph  
**75mm**



**MAIN APPLICATIONS**

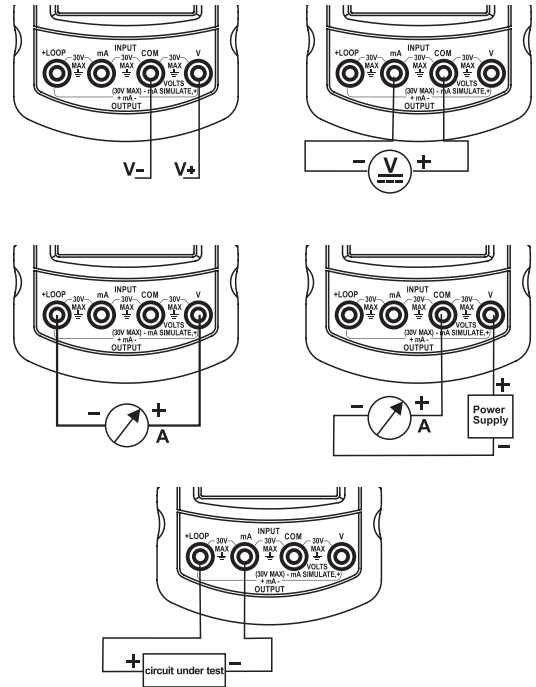

**VOLTAGE AND CURRENT CALIBRATOR**  
**MS7221**

SKU NO: MS7221CBGLO  
UPC CODE: 810053672020  
EAN CODE: 8435394777757

**FEATURE**

- Storage Temperature -40°C~60°C.
- Operating Temperature -10°C~55°C.
- Operating Altitude 3000 meters maximum.
- Vibration : Random 2G, 5Hz~500Hz.

**SPECIFICATIONS**

DC Voltage <b>0~100mV, 0~10V</b>	DC Current <b>0~24mA</b>
-------------------------------------	-----------------------------

**CONTENTS**

- |  |  |  |                             |
|--|--|--|-----------------------------|
|  | 190×89×42mm<br>7.5"×3.5"×1.7"<br>350g/0.77lb |  | 1x9V 6LR61<br>Battery       |
|  | Test leads/Wapping case/<br>Battery          |  | Calibration<br>Certificate  |
|  |  |  | QSG<br>Quick<br>Start Guide |

**PACKAGING INFORMATION**

- |  |                                     |  |                                   |  |                |
|--|-------------------------------------|--|-----------------------------------|--|----------------|
|  | <b>Color Box</b><br>L188×W88×H264mm |  | <b>Carton Box</b><br>47×31×39.5cm |  | <b>X 10PCS</b> |
|--|-------------------------------------|--|-----------------------------------|--|----------------|



**MAIN APPLICATIONS**

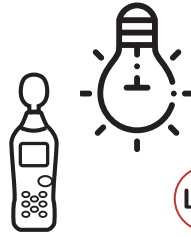

Lux

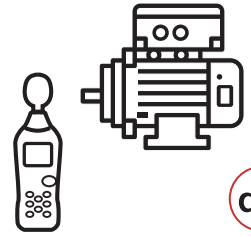

dB



km/h knots m/s FPM

**MULTI-FUNCTIONS ENVIRONMENT TESTER**  
**MS6300**

SKU NO: MS6300CBGLO  
UPC CODE: 810053672594  
EAN CODE: 8435394778235

**FEATURE**

- AVG/MAX/MIN/DIF (MAX-MIN)
- A/C Weighting Indication.
- Data Hold.
- Display Backlight.

**SPECIFICATIONS**

Sound Level <b>30~130dB(A)</b>	Luminance <b>0~50,000LUX</b>	Wind Speed <b>0.5~20m/s</b>
Air Flow <b>999,900CMM/CFM</b>	Humidity <b>20~80%RH</b>	
Temperature <b>-10~60°C/14~140°F</b>		

**CONTENTS**



280×89×50mm  
11.0"×3.5"×2.0"  
433g/0.95lb



1×9V 6F22  
Battery



ACCESSORIES

Windbreak/Holder/Wrapping case/  
Battery



Calibration  
Certificate



Quick  
Start Guide

**PACKAGING INFORMATION**



Color Box  
L325×W80×H160mm



Carton Box  
42×35×35cm



X 10PCS

TEST LEADS

**T3009U**



SKU No.	UPC CODE	EAN CODE
T3009UPEGLO		
- Probe Length: 146mm/ø10.2mm Right Angle Type, M4 screw - Length: 1200mm - Tip: ø2mm		- Plug: ø4.5mm - Wire: UL 1803/18AWG - MAX 10A

TEST LEADS

**T3030U**



SKU No.	UPC CODE	EAN CODE
T3030UPEGLO	810053672778	8435394778419
- Probe Length: 143mm/ø10mm - Length: 1000mm - Tip: ø2mm		- Plug: ø4.5mm - Wire: UL 1803/18AWG - MAX 10A

TEST LEADS

**T3016U**



SKU No.	UPC CODE	EAN CODE
T3016UPEGLO	810053674000	8435394779072
- Probe Length: 132mm/ø10mm Right Angle Type, M4 screw - Length: 1000mm - Tip: ø2mm		- Plug: ø4.5mm - Wire: UL 1803/18AWG - MAX 10A

TEST LEADS

**T3033U**



SKU No.	UPC CODE	EAN CODE
T3033UPEGLO	810053672785	8435394778426
- Probe Length: 119mm/ø9mm - Length: 800mm - Tip: ø2mm		- Plug: ø4.5mm - Wire: UL 1803/20AWG - MAX 10A

TEST LEADS

**T3022**



SKU No.	UPC CODE	EAN CODE
T3022PEGLO	810053674017	8435394779089
- Straight Type & Right Angle Type - Length: 1000mm - Plug: ø4.5mm		- Wire: UL 1803/18AWG - MAX 10A

TEST LEADS

**T3060A**

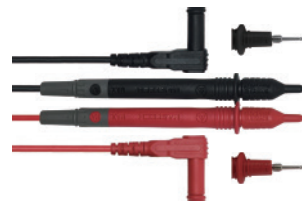

SKU No.	UPC CODE	EAN CODE
T3060APEGLO	810053674819	8435394783482
- Probe Length: 132mm/ø10mm Right Angle Type, M4 screw - Length: 1000mm - Tip: ø2mm		- Plug: ø4.5mm - Wire: UL 1803/18AWG - MAX 10A

TEST LEADS

**T3060B**



SKU No.	UPC CODE	EAN CODE
T3060BPEGLO	810053674826	8435394779881

- Probe Length: 132mm/ø10mm
- Right Angle Type, M4 screw
- Length: 1500mm
- Tip: ø2mm
- Plug: ø4.5mm
- Wire: UL 1803/18AWG
- MAX 10A

TEST LEADS

**T3103**



SKU No.	UPC CODE	EAN CODE
T3103PEGLO	810053674024	8435394779096

- Straight Type
- Length: 1340mm
- Plug: ø4.5mm
- Wire: UL 1803/18AWG
- MAX 10A

Big Mouth Alligator Clip

**C3107**



SKU No.	UPC CODE	EAN CODE
C3107PEGLO	810053674031	8435394779102

- Length: 87mm
- ø4mm cross plug
- Max 32A

Alligator Clip

**C3109A**



SKU No.	UPC CODE	EAN CODE
C3109APEGLO	810053674901	8435394782355

- Length: 61.5mm
- with M4 screw

Medium Alligator Clip

**C3109B**



SKU No.	UPC CODE	EAN CODE
C3109BPEGLO	810053673249	8435394778723

- Length: 55mm
- with M4 screw

IC Test Clip

**C3112**



SKU No.	UPC CODE	EAN CODE
C3112PEGLO	810053675014	8435394783451

- Length: 185mm
- Plug: ø4mm Jack
- Max 5A



THERMOCOUPLES  
**P3400**



SKU No.	UPC CODE	EAN CODE
P3400PEGLO	810053676752	8435394779867

- Length:1000mm  
- Ranging:-40~260°C(-40~500°F)

THERMOCOUPLES  
**P3408A**



SKU No.	UPC CODE	EAN CODE
P3408APEGLO	810053675410	8435394783482

- Length:1000mm  
- Ranging:-40~260°C(-40~500°F)  
- Plug lenth : 12mm

THERMOCOUPLES  
**P3401**



SKU No.	UPC CODE	EAN CODE
P3401PEGLO	810053674888	8435394782096

- Length:1000mm  
- Ranging:-40~260°C(-40~500°F)

THERMOCOUPLES  
**P3409A**



SKU No.	UPC CODE	EAN CODE
P3409APEGLO	810053675434	8435394783505

- Length:1000mm  
- Ranging:-40~600°C(-40~1112°F)  
- Plug lenth : 12mm

THERMOCOUPLES  
**P3408B**



SKU No.	UPC CODE	EAN CODE
P3408BPEGLO	810053675427	8435394783499

- Length:1000mm  
- Ranging:-40~260°C(-40~500°F)  
- Plug lenth : 16mm

THERMOCOUPLES  
**P3409B**



SKU No.	UPC CODE	EAN CODE
P3409BPEGLO	810053674802	8435394779867

- Length:1000mm  
- Ranging:-40~260°C(-40~500°F)  
- Plug lenth : 16mm

THERMOCOUPLES

**P3410**



SKU No.	UPC CODE	EAN CODE
P3410PEGLO	810053675441	8435394783512

- Length:1000mm  
 - Ranging:-40~600°C(-40~1112°F)

THERMOCOUPLES

**P3412**



SKU No.	UPC CODE	EAN CODE
P3412PEGLO	810053675458	8435394783529

- Length:1000mm  
 - Ranging:-40~260°C(-40~500°F)



# MASTECH®



## APAC

**MGL APPA Corporation** ✉ [cs.apac@mgl-intl.com](mailto:cs.apac@mgl-intl.com)  
Flat 4-1, 4/F, No. 35, Section 3 Minquan East Road,  
Taipei, Taiwan  
Tel: +886 2-2508-0877

## CANADA & USA

**MGL AMERICA, INC.** ✉ [cs.na@mgl-intl.com](mailto:cs.na@mgl-intl.com)  
2810 Coliseum Centre Drive, Ste. 100, Charlotte,  
North Carolina 28217 USA  
Tel: +1 833 533-5899

## EMEA

**MGL EUMAN S.L.** ✉ [cs.emea@mgl-intl.com](mailto:cs.emea@mgl-intl.com)  
Parque Empresarial Argame, 33163 Morcín,  
Asturias, Spain.  
Tel: +34 985-08-18-70

## MEXICO & LATAM

**MGL LATAM S.A DE CV** ✉ [cs.latam@mgl-intl.com](mailto:cs.latam@mgl-intl.com)  
Colonia Industrial Vallejo Del. Azcapotzalco 02300,  
Mexico D.F  
Tel: +1 833-533-5899

## UNITED KINGDOM

**MGL GROUP U.K. LIMITED** ✉ [cs.uk@mgl-intl.com](mailto:cs.uk@mgl-intl.com)  
14 Weller St, London, SE1 1QU, UK  
Tel: +34 985-08-18-70

